

HV3

Stop valve

Installation and Maintenance Instructions

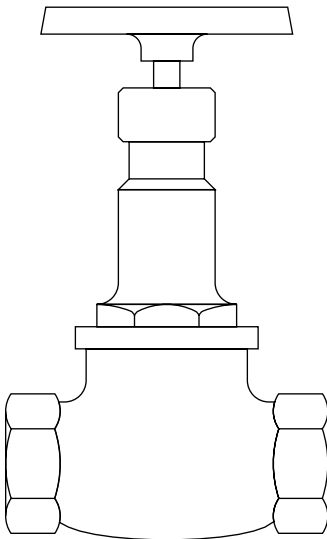

- 1. *General safety information*
- 2. *General product information*
- 3. *Installation*
- 4. *Commissioning*
- 5. *Operation*
- 6. *Maintenance*
- 7. *Spare parts*

1. General safety information

Safe operation of the unit can only be guaranteed if it is properly installed, commissioned and maintained by a qualified person (see Section 11 of the attached Supplementary Safety Information) in compliance with the operating instructions. General installation and safety instructions for pipeline and plant construction, as well as the proper use of tools and safety equipment must also be complied with.

Isolation

Consider whether closing isolating valves will put any other part of the system or personnel at risk. Dangers might include; isolation of vents and protective devices or alarms. Ensure isolation valves are turned off in a gradual way to avoid system shocks.

Pressure

Before attempting any maintenance consider what is or may have been in the pipeline. Ensure that any pressure is isolated and safely vented to atmospheric pressure before attempting to maintain the product, this is easily achieved by fitting Spirax Sarco depressurisation valves type DV (see separate literature for details). Do not assume that the system is depressurised even when a pressure gauge indicates zero.

Temperature

Allow time for temperature to normalise after isolation to avoid the danger of burns and consider whether protective clothing (including safety glasses) is required.

PTFE - Gland packing

If seals made from PTFE have been subjected to a temperature approaching 260°C (500°F) or higher, they will give off toxic fumes, which if inhaled are likely to cause temporary discomfort. It is essential for a no smoking rule to be enforced in all areas where PTFE is stored, handled or processed as inhalation of the fumes from burning tobacco contaminated with PTFE particles can develop 'polymer fume fever'.

Disposal

The product is recyclable. No ecological hazard is anticipated with the disposal of this product providing due care is taken, EXCEPT:

PTFE - Gland packing:

- Waste parts can only be disposed of by an approved method, not incineration.
- Keep PTFE waste in a separate container, do not mix it with other rubbish, and consign it to a landfill site.

— 2. General product information —

2.1 General description

A bronze bodied globe valve for steam, water, oil or air applications. To BS 5154 Series A.
Note: For further information see the following Technical Information Sheet, TI-P060-01, which gives full details of: Materials, sizes and pipe connections, dimensions, weights, operating ranges and capacities.

2.2 Sizes and pipe connections

½", ¾", 1", 1¼", 1½" and 2" screwed BSP parallel.

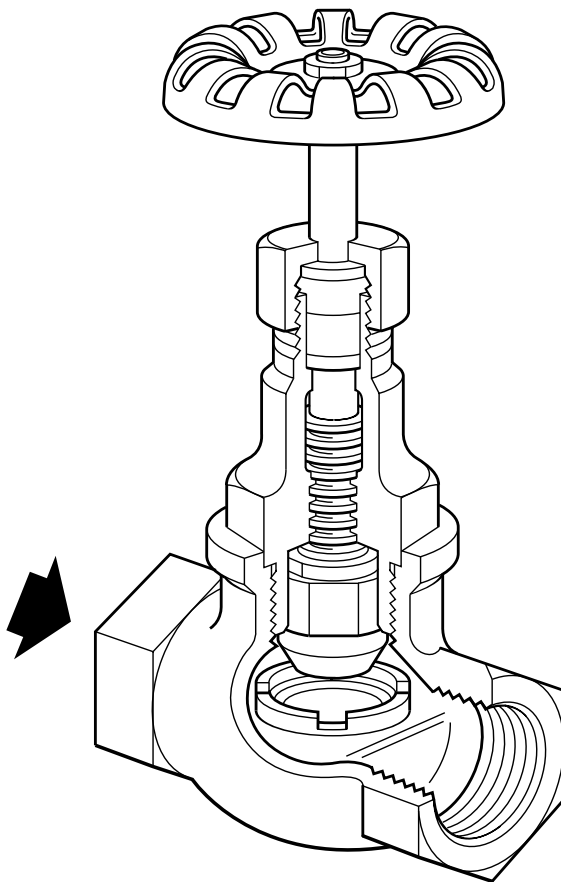
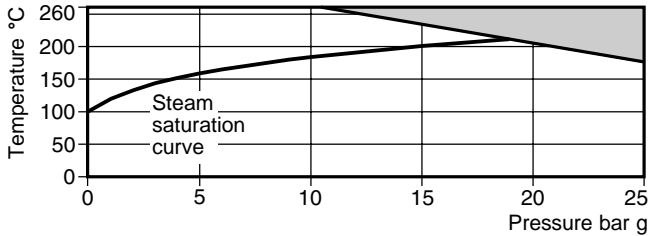



Fig. 1

2.3 Limiting conditions

Maximum body design conditions	PN25	
PMA - Maximum allowable pressure	25 bar g	(362.5 psi g)
TMA - Maximum allowable temperature	260°C	(500°F)
PMO - Maximum operating pressure	25 bar g	(362.5 psi g)
TMO - Maximum operating temperature	260°C	(500°F)
Designed for a maximum cold hydraulic test pressure of:	38 bar g	(551 psi g)

2.4 Operating range



 The product must not be used in this region.

3. Installation

Note: Before actioning any installation observe the 'Safety information' in Section 1.

Wherever practicable, valves should be installed where there is adequate space available so that they can be conveniently operated and maintained.

Before installing a valve, check to ensure that size, pressure rating, materials of construction, end connections, etc. are suitable for the service conditions of the particular application.

Care must be taken to ensure that all dirt which may have accumulated in the valve during storage is removed before installation, maintain cleanliness during installation since the introduction of dirt can result in damage to the valve seats and operating mechanism.

To minimise the danger of abrasive particles damaging the seats, pipeline strainers should be fitted upstream of the valves.

Install the valve in the direction of flow given by the arrow on the body with the handwheel in a suitable position. The preferred position is with the spindle vertical. The valve can be installed from the vertical to the horizontal plane (see Fig. 2 below).

Do not mount the valve upside down.

When installed on steam systems a suitable steam trap should be fitted immediately upstream of the isolation valve. This will ensure drainage of the pipe when the valve is closed, and will prevent damage of the valve due to waterhammer. The drain trap should be either a ball float (FT) or thermodynamic (TD) type. Correct condensate drainage of all upstream pipework is also vital. Always open valves slowly to avoid system shocks.

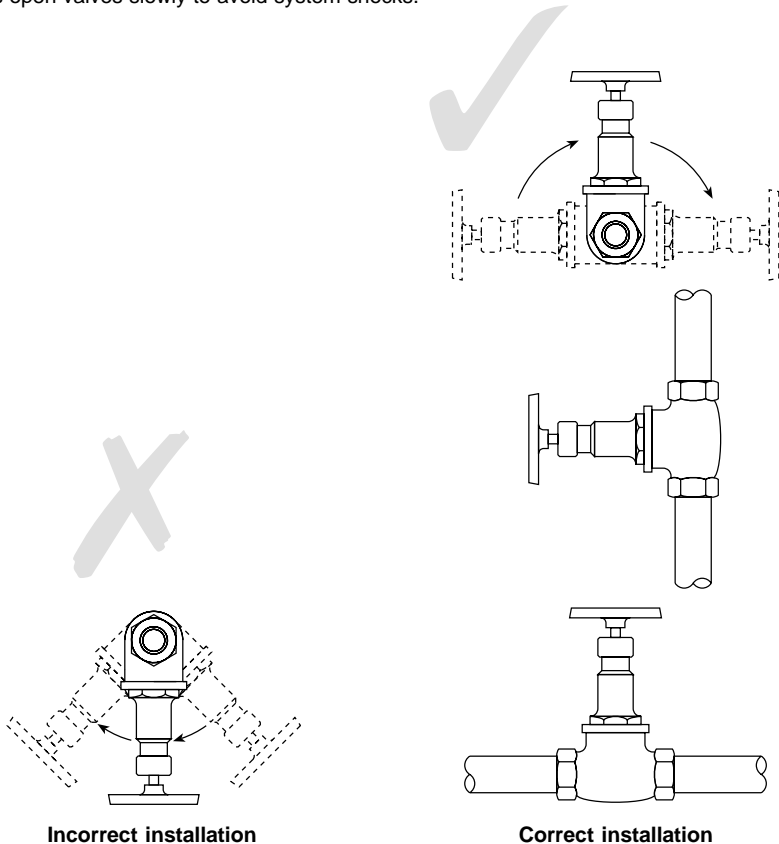

Fig. 2

4. Commissioning

After installation or maintenance ensure that the system is fully functional. Carry out tests on any alarms or protective devices.

5. Operation

The Spirax Sarco HV3 stop valve is operated manually by a handwheel. Special care must be taken to ensure that the movement is made in the correct direction.

To open the valve fully, turn the handwheel clockwise until the shaft is raised to the maximum position, and then lower the shaft by giving the wheel an $\frac{1}{8}$ to $\frac{1}{4}$ turn anticlockwise to remove any backlash. This is to prevent the possibility of attempting to force open a valve, which is already fully open, resulting in damage to the stem or other components.

6. Maintenance

Note: Before actioning any maintenance observe the 'Safety information' in Section 1.

6.1 General information

As with all mechanical devices, regular maintenance is the most efficient means of ensuring continual operational efficiency.

Regular scheduled inspection of the valves is essential, especially on valves which are only occasionally operated.

6.2 How to change the gland packing:

- Isolate the valve and allow the pressure and temperature to normalise.
- Unscrew the handwheel nut (12) and remove the handwheel (11).
- Unscrew the packing nut (10) and remove the gland (9).
- Dispose of the PTFE gland packing by observing the Safety information in Section 1.
- Replace the gland packing.
- Replace the gland (9) and packing nut (10) and tighten as required.
- Replace the handwheel, washer and handwheel nut and tighten as required.
- Open the isolation valves slowly to allow the system pressure to build up.
- Check for leaks.

6.3 How to change the seat and valve assembly:

- Isolate the valve and allow the pressure and temperature to normalise.
- Unscrew the bonnet (5) and remove the valve (3) and seat (2).
Note: Removing the seat requires a special tool, which is available from Spirax Sarco. Contact your local Spirax Sarco office for further details.
- Replace the valve (3) and seat (2) with new parts.
- Replace the bonnet (5) and tighten as required.
- Open the isolation valves slowly to allow the system pressure to build up.
- Check for leaks.

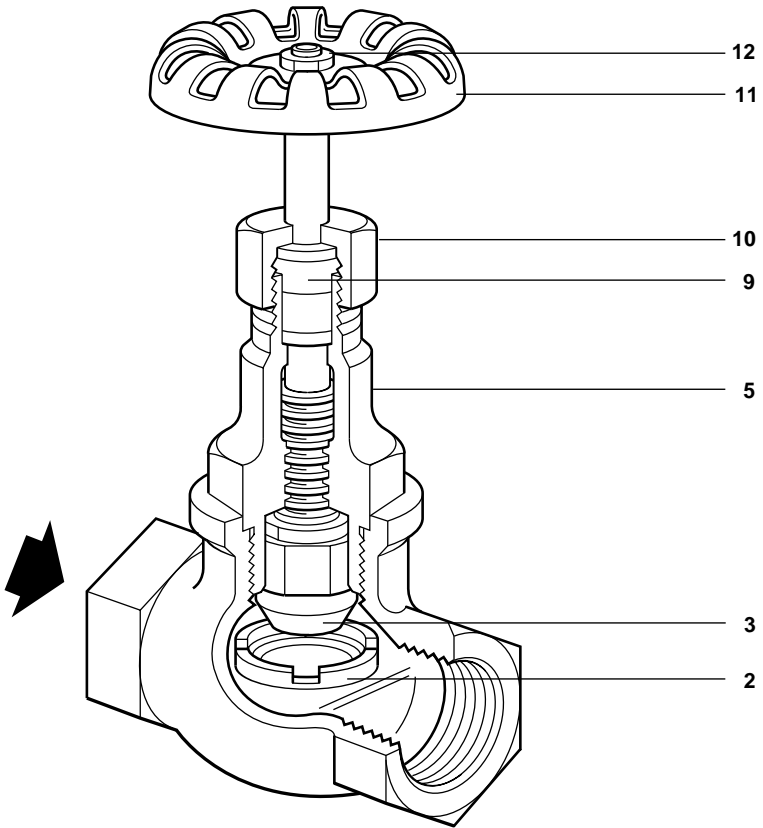



Fig. 2

Table 1 Recommended tightening torques

Item	Part	Size	 or mm		N m	(lbf ft)
2	Seat	1/2"			30	(22)
		3/4"			40	(29)
		1"			45	(32)
		1 1/4"			50	(36)
		1 1/2"			100	(72)
		2"			150	(107)
5	Bonnet	1/2"	25.5 A/F		100	(72)
		3/4"	30.5 A/F		150	(107)
		1"	37.0 A/F		175	(125)
		1 1/4"	42.0 A/F		200	(143)
		1 1/2"	47.0 A/F		250	(179)
		2"	55.5 A/F		380	(272)
10	Packing nut	1/2"	25.5 A/F		20	(14)
		3/4"	25.5 A/F		20	(14)
		1"	25.5 A/F		25	(18)
		1 1/4"	30.5 A/F		40	(29)
		1 1/2"	30.5 A/F		40	(29)
		2"	34.0 A/F		45	(32)

7. Spare parts

The spare parts available are shown in heavy outline. Parts drawn in broken line are not supplied as spares.

Available spares

Valve and seat assembly	2, 3
Gland packing (packet of 3)	8

Important note:

The above spares are applicable to the HV3 stop valve only, identified by its blue handwheel. They are not interchangeable with spares for the HV1 stop valve identified by its green handwheel, or the HV2 stop valve, identified by its red handwheel.

How to order spares

Always order spares by using the description given in the column headed 'Available spares' and state the size and type of valve.

Example: 1 - Valve and seat assembly for a 1" Spirax Sarco HV3 stop valve.

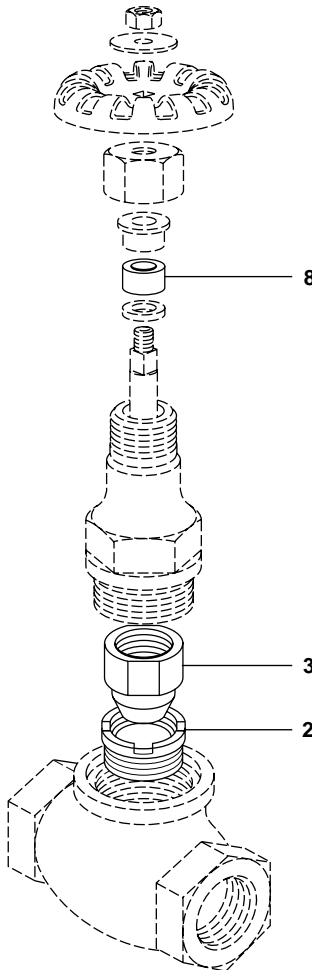

Fig. 3