

Thermodynamic Steam Traps
Installation and Maintenance Instructions

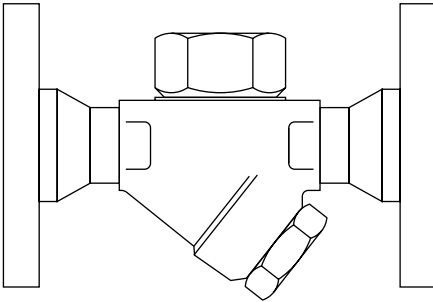

- 1. General
safety information*
- 2. General
product information*
- 3. Installation*
- 4. Commissioning*
- 5. Operation*
- 6. Maintenance*
- 7. Spare parts*

— 1. *General safety information* —

Safe operation of this unit can only be guaranteed if it is properly installed, commissioned and maintained by a qualified person (see Section 11 of the attached Supplementary Safety Information) in compliance with the operating instructions. General installation and safety instructions for pipeline and plant construction, as well as the proper use of tools and safety equipment must also be complied with.

Isolation

Consider whether closing isolating valves will put any other part of the system or personnel at risk. Dangers might include; isolation of vents and protective devices or alarms. Ensure isolation valves are turned off in a gradual way to avoid system shocks.

Pressure

Before attempting any maintenance consider what is or may have been in the pipeline. Ensure that any pressure is isolated and safely vented to atmospheric pressure before attempting to maintain the product, this is easily achieved by fitting Spirax Sarco depressurisation valves type DV (see separate literature for details). Do not assume that the system is depressurised even when a pressure gauge indicates zero.

Temperature

Allow time for temperature to normalise after isolation to avoid the danger of burns and consider whether protective clothing (including safety glasses) is required.

Disposal

The product is recyclable. No ecological hazard is anticipated with the disposal of this product providing due care is taken.

— 2. General product information —

2.1 General description

The TD32F is a medium pressure flanged thermodynamic steam trap with integral strainer screen suitable for mains drainage.

Note: For additional information see the Technical Information Sheet TI-P068-17.

Optional extras

The following (with exception to the DN25) is available as an optional extra and must be specified at the time of order placement.

Insulating cover: To prevent the trap being unduly influenced by excessive heat loss such as when subjected to low outside temperatures, wind, rain etc.

2.2 Sizes and pipe connections

DN 15LC, 15, 20 and 25

Standard flange:- BS 4504 PN40, BS 1560 ANSI Class 150 and 300

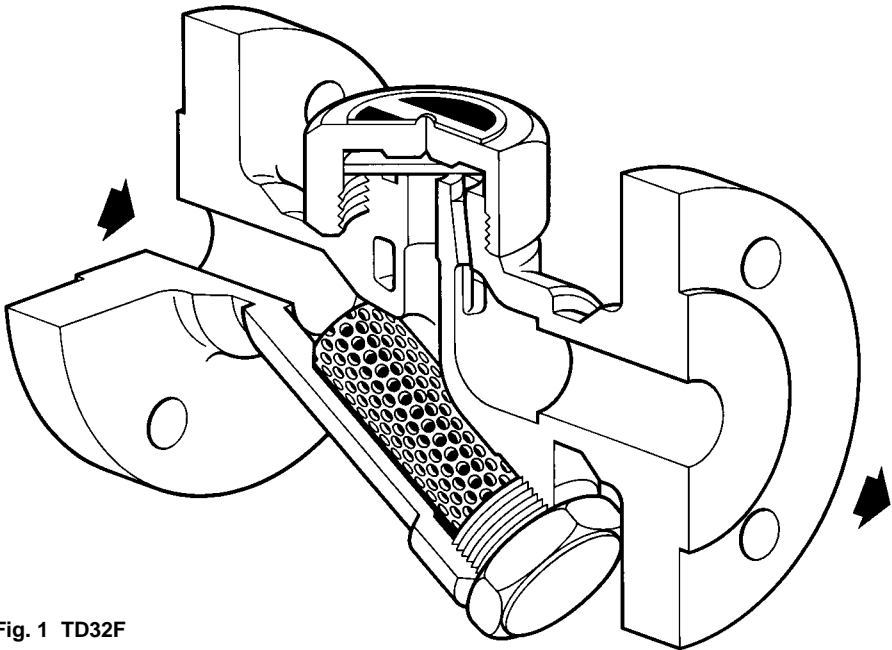

Fig. 1 TD32F

2.3 Limiting conditions (ISO 6552)

Body design conditions		PN40	
PMO - Maximum operating pressure		32 bar g	(464 psi g)
TMO - Maximum operating temperature	TD32F	400°C	(752°F)
	TD32A	255°C	(491°F)
PMA - Maximum allowable pressure		40 bar g	(580 psi g)
TMA - Maximum allowable temperature		400°C	(752°F)
PMOB - Maximum operating back pressure 80% of the upstream pressure.			
Designed for a maximum cold hydraulic test pressure of:		60 bar g	(870 psi g)

Note:- Minimum operating pressure for satisfactory operation is 0.25 bar g (3.6 psi g).

2.4 Operating range

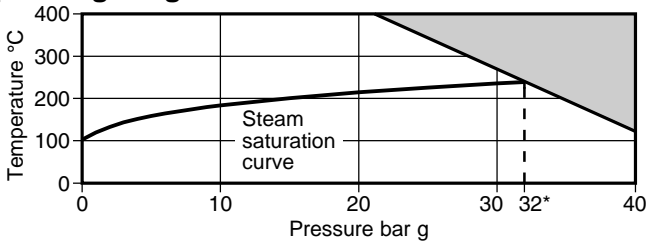

 The product must not be used in this region.

* PMO - Maximum operating pressure (recommended) 32 bar g (464 psi g).

PMOB - Maximum operating back pressure is 80% of the upstream pressure.

Note:- Minimum operating pressure for satisfactory operation is 0.25 bar g (3.6 psi g).

3. Installation

Note: Before actioning any installation observe the 'Safety information' in Section 1.

Referring to the Installation and Maintenance Instructions, name-plate and Technical Information Sheet, check that the product is suitable for the intended installation:

- 3.1** Check materials, pressure and temperature and their maximum values. If the maximum operating limit of the product is lower than that of the system in which it is being fitted, ensure that a safety device is included in the system to prevent overpressurisation.
- 3.2** Determine the correct installation situation and the direction of fluid flow.
- 3.3** Remove protective covers from all connections.
- 3.4** The trap should preferably be installed in the horizontal plane, with a small drop leg preceding it. Suitable isolation valves must be installed to allow for safe maintenance and trap replacement. Consideration should be given to a suitable method for testing the correct operation of the trap. This may be a sight glass or a Spiratec system. Sight glasses must be positioned a minimum of 1 m (3 ft) downstream of any blast-action traps. Where the trap discharges into a closed return system, a non-return valve should be fitted downstream to prevent return flow. Remove all packaging and protective covers and ensure all connection ports are clear from obstruction.

Always open isolation valves slowly until normal operating conditions are achieved - this will avoid system shocks. Check for leaks and correct operation. Always ensure the correct tools, safety procedures and protective equipment are used at all times.

Note: If the trap is to discharge to atmosphere ensure it is to a safe place, the discharging fluid may be at a temperature of 100°C (212°F).

4. Commissioning

After installation or maintenance ensure that the system is fully functional. Carry out tests on any alarms or protective devices.

5. Operation

The thermodynamic steam trap will discharge condensate with a blast type action at a few degrees below steam saturation temperature, due care must be given to the site of the discharge.

6. Maintenance

Note: Before actioning any maintenance programme observe the 'Safety information' in Section 1.

6.1 General information

Before undertaking any maintenance on the trap it must be isolated from both the supply line and return line and any pressure allowed to safely normalise to atmosphere. The trap should then be allowed to cool. When reassembling, ensure that all joint faces are clean.



6.2 How to service

- Remove insulating cover (7), if fitted, and unscrew the cap (2) using a suitable spanner or socket. Do not use stillsons or a wrench of similar type which may cause distortion of the cap.
- If the seating faces on the body are only slightly worn, they can be refaced by lapping on a flat surface, such as a surface plate. A figure-of-eight motion and a little grinding compound, such as 'Carborundum Co's Compound I.F.' gives the best results. If the wear is too great to be rectified by simple lapping, the seating faces on the body must be ground flat and then lapped. **Note: the disc (3) should always be replaced with a new one.** The total amount of metal removed in this way should not exceed 0.25 mm (0.010").
- When reassembling, the disc (3) is normally placed in position with the grooved side in contact with the body seating face.
- Screw on the cap (2) to the recommended tightening torque (see Table 1); no gasket is required but a suitable high temperature anti-seize grease should be applied to the threads.

6.2 How to clean or replace the strainer:

- Unscrew the strainer cap (5) using a suitable spanner.
- Withdraw the screen (4) and clean or, if damaged, replace with a new one.
- To reassemble, insert the screen (4) into the strainer cap (5), then screw the strainer cap into place. A fine smear of 'Molybdenum Disulphide' grease should be applied to the first few threads. Care should be taken to ensure that the gasket and gasket faces are clean.
- Tighten to the recommended torque (see Table 1).
- When maintenance is complete open isolation valves slowly and check for leaks.

Table 1 Recommended tightening torques

Item	Part	 or  mm	N m	(lbf ft)
2	Cap	DN15LC	36 A/F	135 - 150 (100 - 110)
		DN15	36 A/F	180 - 200 (132 - 147)
		DN20	41 A/F	180 - 200 (132 - 147)
		DN25	55 A/F	250 - 275 (184 - 202)
5	Strainer cap	32 A/F M28	170 - 190 (125 - 140)	

7. Spare parts

The spare parts available are shown in heavy outline. Parts shown in broken line are not supplied as spares.

Available spares

Disc	(packet of 3)	3
Strainer screen and gasket		4, 6
Strainer cap gasket (packet of 3)		6
Insulating cover		7

How to order spares

Always order spare parts by using the description given in the column headed 'Available spares' and state the size.

Example: 1 off Strainer screen and gasket to suit a DN15 Spirax Sarco TD32F.

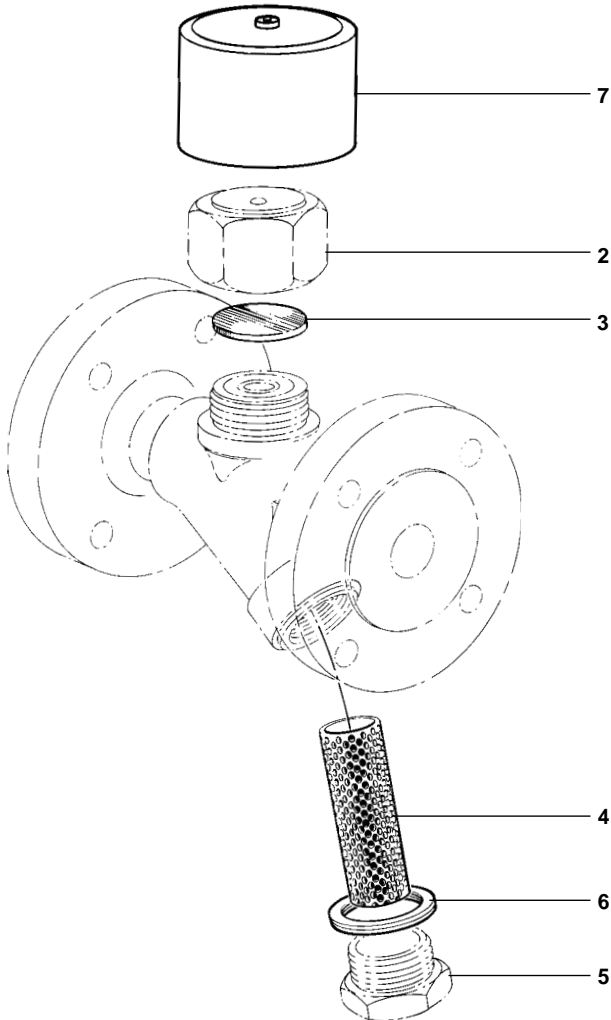

Fig. 2

