

FT43, FT44, FT46 and FT47
Ball Float Steam Traps
Installation and Maintenance Instructions

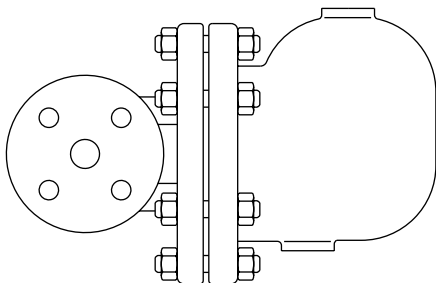

1. *General safety information*
2. *General product information*
3. *Installation*
4. *Commissioning*
5. *Operation*
6. *Maintenance and Spare parts*

— 1. *General safety information* —

Safe operation of these units can only be guaranteed if they are properly installed, commissioned and maintained by a qualified person (see Section 11 of the attached Supplementary Safety Information) in compliance with the operating instructions. General installation and safety instructions for pipeline and plant construction, as well as the proper use of tools and safety equipment must also be complied with.

Warning

The cover gasket contains a thin stainless steel support ring which may cause physical injury if not handled and disposed of carefully.

Isolation

Consider whether closing isolating valves will put any other part of the system or personnel at risk. Dangers might include; isolation of vents and protective devices or alarms. Ensure isolation valves are turned off in a gradual way to avoid system shocks.

Pressure

Before attempting any maintenance consider what is or may have been in the pipeline. Ensure that any pressure is isolated and safely vented to atmospheric pressure before attempting to maintain the product, this is easily achieved by fitting Spirax Sarco depressurisation valves type DV (see separate literature for details). Do not assume that the system is depressurised even when a pressure gauge indicates zero.

Temperature

Allow time for temperature to normalise after isolation to avoid the danger of burns and consider whether protective clothing (including safety glasses) is required.

Disposal

These products are recyclable. No ecological hazard is anticipated with the disposal of these products providing due care is taken.

— 2. General product information —

2.1 General description

The FT range of ball float traps can be supplied in cast iron, carbon steel, stainless steel and SG iron. A TÜV approved foundry produces the bodies and covers for the FT44, FT46 and FT47. All ball float traps are fitted with an integral automatic air venting facility and the range is available with horizontal flanged connections or vertical flanged connections designated suffix 'V'. A steam lock release option is also available designated suffix 'C'.

If required, the covers can be drilled and tapped $\frac{3}{8}$ " BSP or NPT for the purpose of fitting a drain valve.

Note: For additional information see the following Technical Information Sheets:

Product		Material	Section	TI reference	Capacities
FT43	DN25 - 50	Cast iron	Section 2.2	TI-S02-21	TI-S02-35
	DN80 - 100	Cast iron	Section 2.2	TI-S02-22	TI-S02-35
FT44	DN15 - 50	Carbon steel	Section 2.3	TI-S02-14	TI-S02-36
	DN80 - 100	Carbon steel	Section 2.3	TI-S02-23	TI-S02-36
FT46	DN15 - 50	Stainless steel	Section 2.4	TI-P143-01	TI-S02-36
FT47	DN15 - 50	SG iron	Section 2.5	TI-P142-01	TI-S02-36

2.2 FT43 - Cast iron

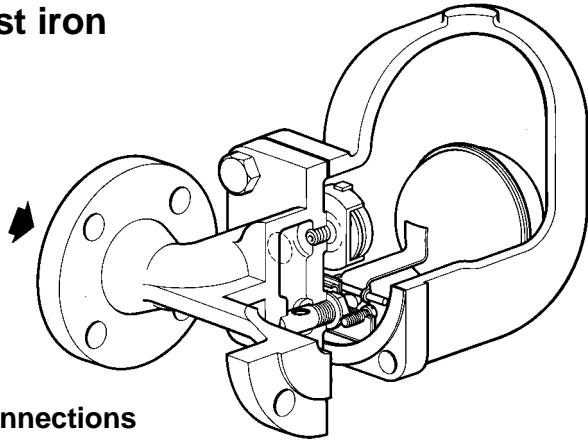

Fig. 1 DN25 shown

Sizes and pipe connections

Horizontal - DN25, 40, 50, 80 and 100

Vertical - DN25, 40 and 50

Standard flanges are BS 4504 and PN16. On request JIS/KS 10, ANSI 125 and ANSI 150 flat face flanges with drilled and tapped holes can be provided.

Limiting conditions (ISO 6552)

Body design conditions	PN16	
PMA - Maximum allowable pressure	16 bar g	(232 psi g)
TMA - Maximum allowable temperature	220°C	(428°F)
PMO - Maximum operating pressure	13 bar g	(188 psi g)
TMO - Maximum operating temperature	220°C	(428°F)
Designed for a maximum cold hydraulic test pressure of:	24 bar g	(348 psi g)

Operating range

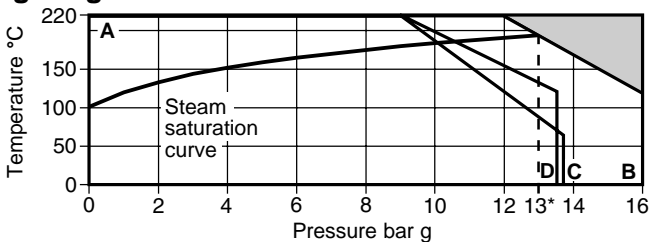

 The product must not be used in this region.

* PMO Maximum operating pressure recommended for saturated steam is 13 bar g (188 psi g).

A - B Flanged BS 4504 PN16 (DN25 to 100).

A - C Flanged ANSI 150 flat face and ANSI 125 (DN25 to 50).

A - D Flanged JIS/KS 10 (DN25 and 100).

ΔPMX - Maximum differential pressure

Size	FT43-4.5	FT43-10	FT43-14
DN25 to 100	4.5 bar	10 bar	13 bar

Note: The FT43 range of float traps are limited to a PMO equal to ΔPMX.

2.3 FT44 - Carbon steel

Fig. 2 DN15 shown

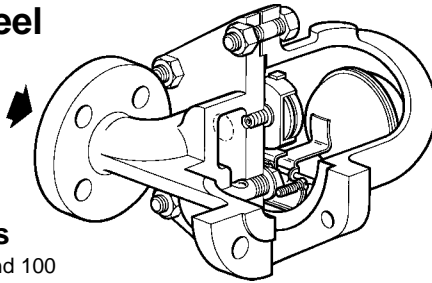

Sizes and pipe connections

Horizontal - DN15, 20, 25, 40, 50, 80 and 100

Vertical - DN15, 20, 25, 40 and 50

Standard flanges are BS 4504/DIN PN40 with face-to-face dimensions in accordance with EN 26554 (Series 1). ANSI B 16.5 Class 150 and 300 and JIS/KS 20* are also available with extended face-to-face dimensions (*vertical traps are in accordance with EN 26554 - Series 1). ANSI/JIS/KS flanges are supplied with tapped holes to receive flange bolts. ANSI flanges have UNC threads and JIS/KS have metric threads.

Limiting conditions (ISO 6552)

Body design conditions	PN40	
PMA - Maximum allowable pressure	40 bar g	(580 psi g)
TMA - Maximum allowable temperature	400°C	(752°F)
PMO - Maximum operating pressure	32 bar g	(464 psi g)
TMO - Maximum operating temperature	300°C	(572°F)
Designed for a maximum cold hydraulic test pressure of:	60 bar g	(870 psi g)

Note: The trap in its complete operational form must not be subjected to a pressure greater than 48 bar g (696 psi g) otherwise damage to the mechanism may result.

Operating range

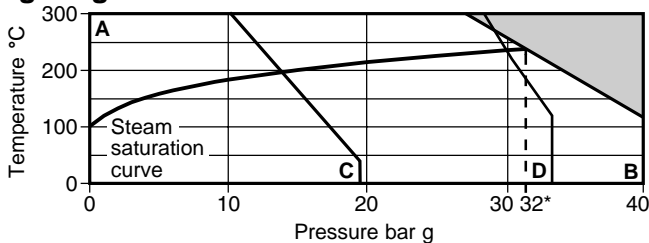

The product must not be used in this region.

* PMO Maximum operating pressure recommended for saturated steam is 32 bar g (464 psi g).

A - B Flanged BS 4504 PN40 and ANSI 300.

A - C Flanged ANSI 150.

A - D Flanged JIS/KS 20.

ΔPMX - Maximum differential pressure

Size	FT44-4.5	FT44-10	FT44-14	FT44-21	FT44-32
DN15, 20 and 25	4.5 bar	10 bar	14 bar	21 bar	32 bar
DN40, 50, 80 and 100	4.5 bar	10 bar	-	21 bar	32 bar

Note: The DN40, 50, 80 and 100, FT44 float traps are limited to a PMO equal to ΔPMX.

2.4 FT46 - Stainless steel

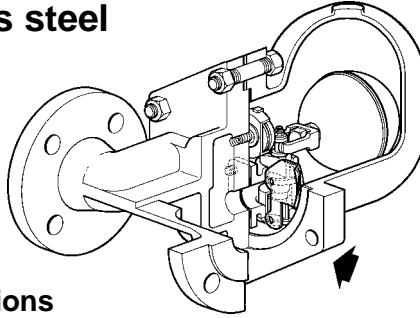

Fig. 3 DN50 shown

Sizing and pipe connections

DN15, 20, 25, 40 and 50

Standard flanges are BS 4504/DIN PN40 with face-to-face dimensions in accordance with EN 26554 (Series 1). ANSI B 16.5 Class 150 and 300 flanges are also available with face-to-face dimensions in accordance with EN 26554 (Series 1). ANSI flanges are supplied with tapped (UNC) holes for flange bolts.

Limiting conditions (ISO 6552)

Body design conditions	PN40	
PMA - Maximum allowable pressure	40 bar g	(580 psi g)
TMA - Maximum allowable temperature	400°C	(752°F)
PMO - Maximum operating pressure	25.5 bar g	(369 psi g)
TMO - Maximum operating temperature	300°C	(572°F)
Designed for a maximum cold hydraulic test pressure of:	60 bar g	(870 psi g)

Note: The trap in its complete operational form must not be subjected to a pressure greater than 48 bar g (696 psi g) otherwise damage to the mechanism may result.

Operating range

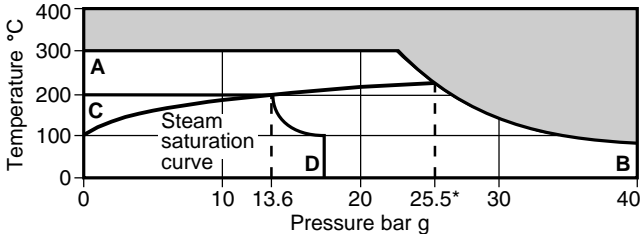

 The product must not be used in this region.

* PMO Maximum operating pressure recommended for saturated steam is 25.5 bar g (369 psi g).

A - B Flanged BS 4504 PN40 and ANSI 300.

C - D Flanged ANSI 150.

ΔPMX - Maximum differential pressure

Size	FT46-4.5	FT46-10	FT46-14	FT46-21	FT46-32
DN15, 20 and 25	4.5 bar	10 bar	14 bar	21 bar	32 bar
DN40 and 50	4.5 bar	10 bar	-	21 bar	32 bar

Note: The DN40 and 50, FT46 float traps are limited to a PMO equal to ΔPMX.

2.5 FT47 - SG iron

Fig. 4 DN50 shown

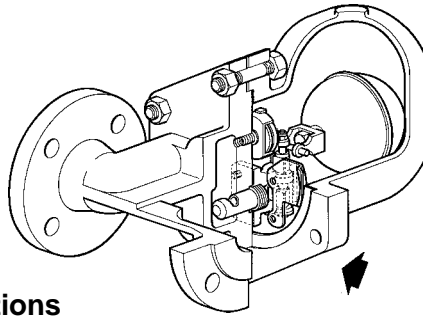

Sizing and pipe connections

DN15, 20, 25, 40 and 50

Standard flanges are BS 4504/DIN PN40/PN25 with face-to-face dimensions in accordance with EN 26554 (Series 1). On request ANSI B 16.5 Class 150 flanges can be supplied with face-to-face dimensions in accordance with EN 26554 (Series 1). Flanges have tapped (UNC) bolt holes on Class 150 versions.

Limiting conditions (ISO 6552)

Body design conditions	PN40	
PMA - Maximum allowable pressure	40 bar g	(580 psi g)
TMA - Maximum allowable temperature	300°C	(572°F)
PMO - Maximum operating pressure	32 bar g	(464 psi g)
TMO - Maximum operating temperature	300°C	(572°F)
Designed for a maximum cold hydraulic test pressure of:	60 bar g	(870 psi g)

Note: The trap in its complete operational form must not be subjected to a pressure greater than 48 bar g (696 psi g) otherwise damage to the mechanism may result.

Operating range

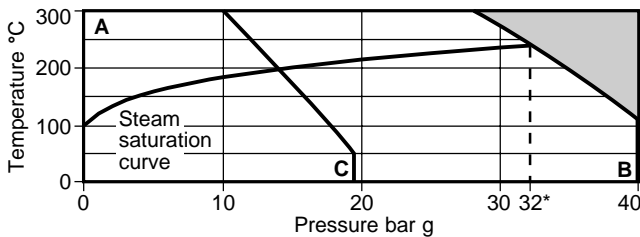

The product must not be used in this region.

* PMO Maximum operating pressure recommended for saturated steam is 32 bar g (464 psi g).

A - B Flanged BS 4504 PN40.

A - C Flanged ANSI 150.

ΔPMX - Maximum differential pressure

Size	FT47-4.5	FT47-10	FT47-14	FT47-21	FT47-32
DN15, 20 and 25	4.5 bar	10 bar	14 bar	21 bar	32 bar
DN40 and 50	4.5 bar	10 bar	-	21 bar	32 bar

Note: The DN40 and 50, FT47 float traps are limited to a PMO equal to ΔPMX.

3. Installation

Note: Before actioning any installation observe the 'Safety information' in Section 1.

Warning

The cover gasket contains a thin stainless steel support ring, which may cause physical injury if not handled and disposed of carefully.

Referring to the Installation and Maintenance Instructions, name-plate, and Technical Information Sheet, check that the product is suitable for its intended use.

- 3.1** Check materials, pressure and temperature and their maximum values. If the maximum operating limit of the product is lower than that of the system in which it is being fitted, ensure that a safety device is included in the system to prevent overpressurisation.
- 3.2** Determine the correct installation situation and direction of fluid flow – please be aware that the flow direction is not the same for all FT trap types or sizes. However the flow direction will be clearly marked on the trap body.
- 3.3** Remove protective covers from all connections.
- 3.4** The trap must be fitted with the float arm in a horizontal plane so that it rises and falls vertically. Note: The trap can be visually checked for its correct orientation by reading the writing on the body, cover, and name-plate. If installed correctly the writing will be seen to be displayed the correct way up.
- 3.5** The trap should be fitted below the outlet of the steam system, with a small drop leg immediately preceding the trap, typically 150 mm (6") . See Fig. 5. If no drop leg is allowed for then it may be possible (under low load conditions) for steam to flow over the condensate in the bottom of the pipe and reach the trap.

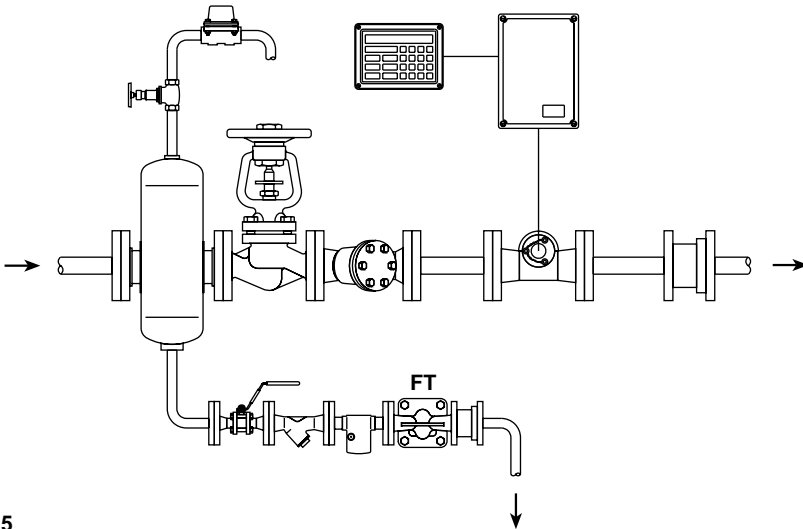

Fig. 5

3.6 Float traps should be fitted as close to the outlet of the plant to be drained as possible otherwise the trap can steam lock. Steam locking occurs when the pipe between the condensate outlet and the steam trap fills with steam and prevents condensate from reaching the trap. This can lead to the system waterlogging which will affect plant efficiency. It is very similar to the air locking experienced in water systems.

The most common application where steam locking is a risk is on rotating cylinders and other applications where condensate is removed via a dip tube or siphon pipe. Steam locking can easily be prevented by fitting the trap with a combined thermostatic air vent and steam lock release valve (SLR), Fig. 6 shows an FT-C trap fitted on a slow speed cylinder.

The SLR valve is opened by turning the spindle anticlockwise. The standard factory setting is $\frac{1}{2}$ turn which equates to an approximate steam 'bypass' of 22 kg/h @ 10 bar.

Site adjustment of the SLR can be achieved by turning anticlockwise to increase the bypass flow, and clockwise to reduce the flow.

When draining from a high speed cylinder application, there is need for large amounts of blow-through steam to assist the flow of condensate out of the cylinder via the siphon tube. In such cases the SLR cannot handle such large amounts and an external bypass with an adjustable needle valve is required. See Fig. 7.

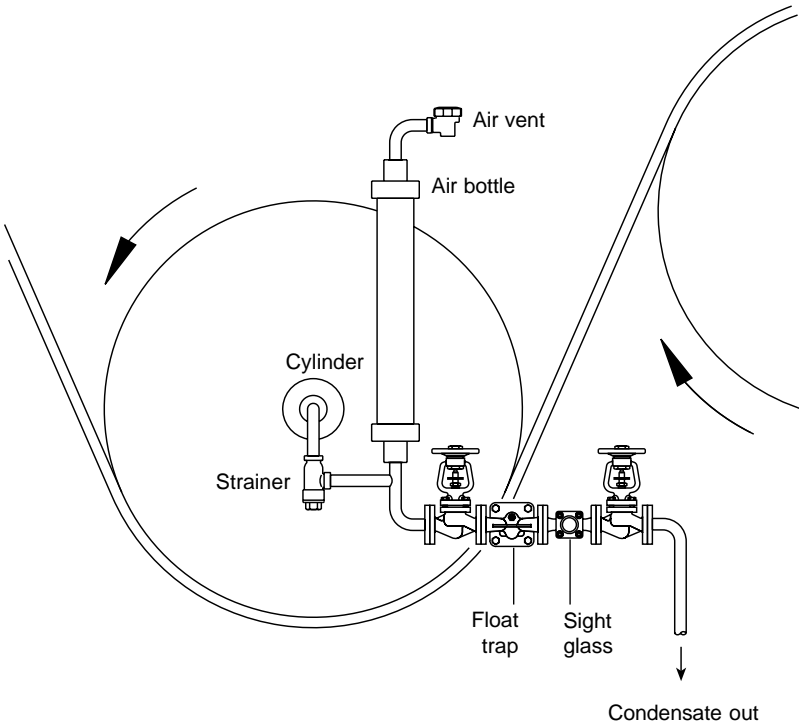

Fig. 6 Slow speed cylinder drainage with system unit

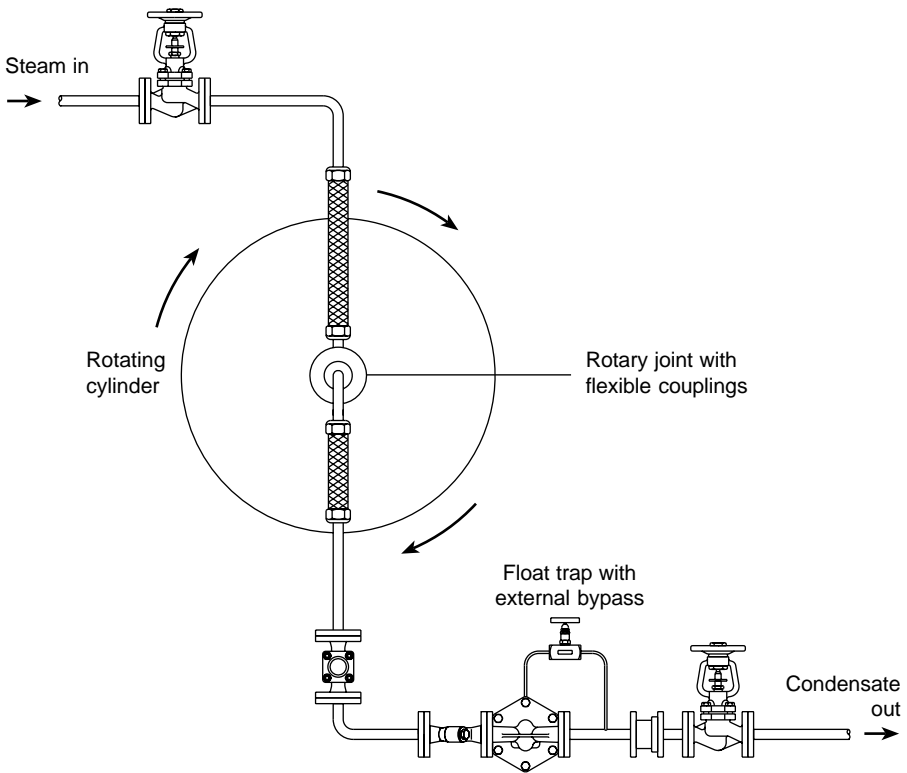

Fig. 7 High speed cylinder with float trap and parallel blow-through valve

- 3.7** If the trap is to be situated in an exposed position, it should be either lagged or drained by a separate small thermostatic trap such as the Spirax Sarco No.8, or Bydrain.
- 3.8** Always fit a non-return (check) valve downstream of any steam trap which discharges into condensate return lines where back pressure is experienced. This is not commonly caused by a rising condensate line. The check valve will prevent the steam space flooding when the inlet pressure is reduced or the steam is shut off.
- 3.9** Ensure adequate space is left to remove the cover from the body for maintenance – the maximum withdrawal to remove the cover is 200 mm (8").

Note: If the trap is to discharge to atmosphere ensure it is to a safe place, the discharging fluid may be at a temperature of 100°C (212°F).

4. Commissioning

After installation or maintenance ensure that the system is fully functioning. Carry out tests on any alarms or protective devices.

5. Operation

The float trap is a continuous trap, removing condensate the instant it forms. On start-up, the thermostatic air vent allows air to bypass the main valve preventing the system air binding. Hot condensate will close the air vent tightly, but as soon as it enters the main chamber of the trap, the float rises and the lever mechanism attached to it opens the main valve - keeping the system drained of condensate at all times. When the steam arrives, the float drops and closes the main valve. Float traps are renowned for their high start-up load handling capability, clean tight shut-off and resistance to waterhammer and vibration.

— 6. Maintenance and Spare parts —

6.1 FT43, FT44, FT46 and FT47 (DN15 to 50)

Note:

Before actioning any maintenance programme observe the 'Safety information' in Section 1.

Warning

The cover gasket contains a thin stainless steel support ring which may cause physical injury if not handled and disposed of carefully.

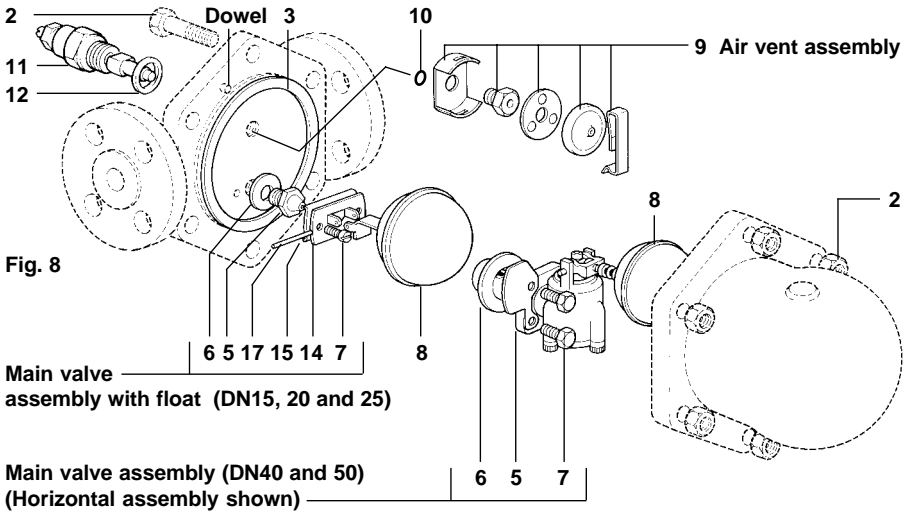



Table 1 Recommended tightening torques

Item No.	Size		or mm		N m	(lbf ft)
* 2	DN15, 20, 25	17 A/F		M10 x 30	29 - 33	(19 - 24)
	DN40	24 A/F		M12 x 60	60 - 66	(44 - 48)
	DN50	24 A/F		M16 x 70	80 - 88	(58 - 65)
5	DN15, 20, 25				50 - 55	(37 - 40)
7	DN15, 20, 25			M5 x 20	2.5 - 2.8	(1.8 - 2.1)
	DN40	10 A/F		M6 x 20	10 - 12	(7.0 - 9.0)
	DN50	13 A/F		M8 x 20	20 - 24	(15 - 17)
9		17 A/F			50 - 55	(37 - 40)
* 11		22 A/F			40 - 45	(29 - 33)
* FT44 only						
2	DN15, 20, 25	17 A/F		M10 x 30	19 - 22	(14 - 16)
11		22 A/F			50 - 55	(37 - 40)

Servicing:

- With suitable isolation, repairs can be carried out with the trap in the pipeline.
- When reassembling, make sure that all joint faces are clean and the dowel locates in the cover.

How to fit the main valve assembly for DN15, DN20 and DN25:

- Unscrew the support frame (15), pivot frame (14) and the valve seat (5).
- Ensure the seat/gasket faces are clean and dry.
- Fit the new gasket (6) and the valve seat (5) to the body (**Do not use gasket paste**).
- Attach the support frame (15) and pivot frame (14) to the body with the assembly set screws (7) but do not tighten.
- Fit the float arm (8) to the pivot frame (14) using the pin (17) and by moving the complete assembly centre the valve head onto the seat orifice.
- Tighten the assembly set screws (see Table 1 for the recommended tightening torques).

How to fit the main valve assembly for DN40 and DN50:

- Unscrew the 4 bolts or nuts (7).
- Remove the main valve assembly (5) and gasket (6).
- Ensure the gasket faces are clean and dry.
- Fit the new gasket (6) and the main valve assembly (5), including the baffle plate (see page 16, Figs. 10 and 11).
- Tighten the bolts or nuts (7) evenly (see Table 1 for recommended tightening torques).

How to fit the air vent assembly for DN15 to DN100:

- Remove the spring clip, capsule, spacer plate, unscrew the seat and remove the frame (9) and gasket (10).
- Ensure the gasket faces are clean and dry.
- Fit the new gasket (10), the frame and seat (9) and tighten to the recommended torque (see Table 1).
- Assemble the new spacer plate, capsule and clip.

Note: Older models of the 32 bar traps were fitted with a bimetallic air vent, this can be replaced with a new capsule assembly.

Spare parts

The spare parts available are shown in heavy outline. Parts drawn in broken line are not supplied as spares.

Available spares

Main valve assembly with float (DN15, 20 and 25) (specify horizontal or vertical traps)	5, 6, 7, 8, 14, 15, 17
Main valve assembly with erosion deflector (DN40 and 50) (specify horizontal or vertical trap)	5, 6, 7
Ball float and lever (DN40 and 50)	8
Air vent assembly	9, 10
Steam lock release and air vent assembly	9, 10, 11, 12
Complete set of gaskets (packet of 3 sets)	6, 10, 12, 13

How to order spares

Always order spares by using the description given in the column headed 'Available spares' and state the size, type of trap, connection: horizontal or vertical and pressure range.

Example: 1 - Air vent assembly for a DN20 Spirax Sarco FT43 ball float steam trap, with horizontal connectors.

6.2 FT43 and FT44 (DN80 and 100)

Note:

Before actioning any maintenance programme observe the 'Safety information' in Section 1.

Warning

The cover gasket contains a thin stainless steel support ring which may cause physical injury if not handled and disposed of carefully.

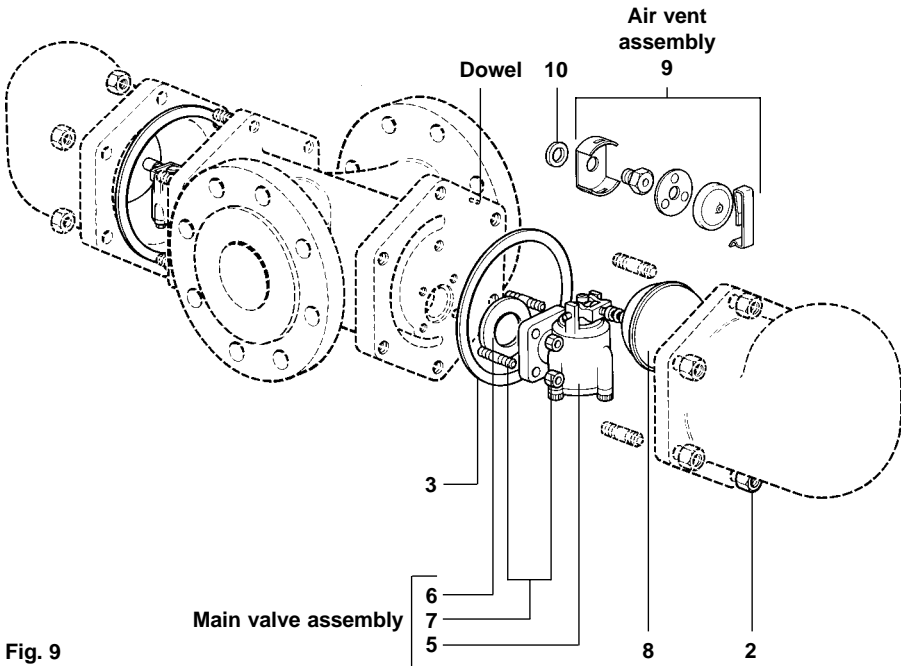



Table 2 Recommended tightening torques

Item No.		or		N m	(lbf ft)
		mm			
2	24 A/F		M16 x 45	80 - 88	(58 - 65)
7	13 A/F		M8 x 20	20 - 24	(15 - 17)
9	17 A/F			50 - 55	(37 - 40)

How to fit the main valve assembly:

- Remove the cover nuts (2) and cover.
- Undo the 4 main valve assembly nuts (7).
- Remove the main valve assembly (5) and gasket (6).
- Ensure gasket faces are clean and dry.
- Fit new gasket (6) and main valve assembly (5).
- Tighten nuts (7) evenly (see Table 2 for the recommended tightening torques).
- Re-use or replace the ball float (8) as required.
- Replace cover gasket (3) ensuring the gasket face has been cleaned.
- Replace the cover, ensuring the dowel is located correctly.
- Retighten the cover nuts (2) evenly (see Table 2 for the recommended tightening torques).

How to fit the air vent assembly:

- Remove the spring clip, capsule, spacer plate, unscrew the seat and remove the frame (9) and gasket (10).
- Ensure the gasket faces are clean and dry.
- Fit the new gasket (10), frame and seat (9) and tighten evenly (see Table 2 for the recommended tightening torques).
- Assemble new spacer plate, capsule and clip.

Note: Older models of the 32 bar traps were fitted with a bimetallic air vent, this can be replaced with a new capsule assembly.

Spare parts

The spare parts available are shown in heavy outline. Parts drawn in broken line are not supplied as spares.

Available spares

Main valve assembly	5, 6, 7
Ball float and lever	8
Air vent assembly	9, 10
Set of all gaskets	3, 6, 10

Note: For a complete overhaul 2 off of each spare are required.

How to order spares

Always order spare parts by using the description given in the column headed 'Available spares' and state the size, Model No. and pressure rating of the trap.

Example: 1 - Main valve assembly for a DN80 Spirax Sarco FT43-10TV ball float steam trap.

6.3 FT mechanisms (DN40 only)

Baffle arrangement used on FT43, FT44, FT46 and FT47 (horizontal only)

In line with our policy of continuous product improvement, we have found it beneficial to add a baffle plate over the inlet port.

This eliminates any risk of flow from the inlet port affecting the correct operation of the float. When fitting the mechanism, assemble the baffle plate supplied under the mechanism retaining bolts.

The correct positioning is shown below.

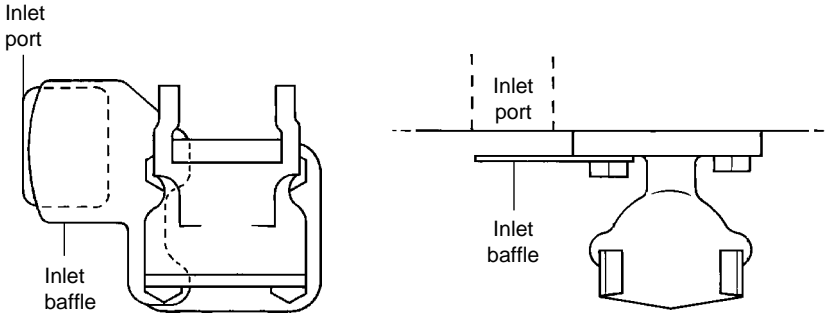

Fig. 10

6.4 FT mechanisms (DN50 only)

Baffle arrangement used on FT43, FT44, FT46 and FT47 (horizontal only)

When fitting the mechanism, assemble as follows:

1. Remove two uppermost studs and replace with the longer studs provided.
2. Assemble the mechanism over the four studs.
3. Place the spacer collars then baffle plate over the longer studs so that the collars rest on the back of the square flange.
4. Replace the nuts and tighten as normal.

The correct assembly and positioning is shown below.

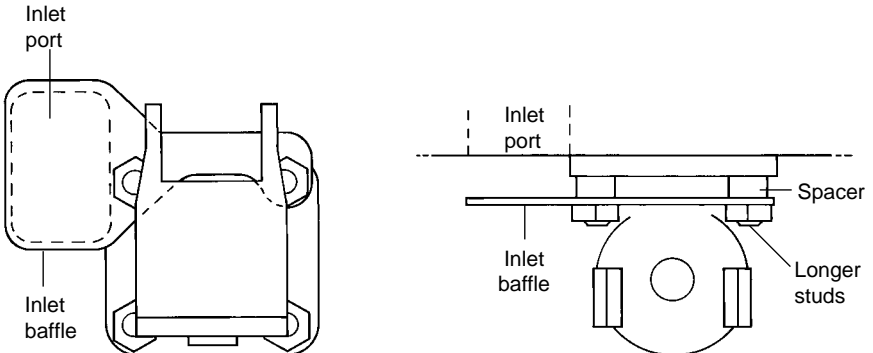

Fig. 11