

DCV1, DCV2 and DCV3
Disc Check Valves
Installation and Maintenance Instructions

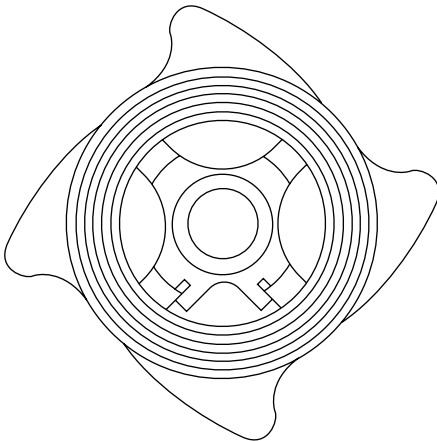

1. *General safety information*
2. *General product information*
3. *Installation*
4. *Commissioning*
5. *Operation*
6. *Maintenance*
7. *Spare parts*

1. General safety information

Safe operation of the unit can only be guaranteed if it is properly installed, commissioned and maintained by a qualified person (see Section 11 of the attached Supplementary Safety Information) in compliance with the operating instructions. General installation and safety instructions for pipeline and plant construction, as well as the proper use of tools and safety equipment must also be complied with.

Isolation

Consider whether closing isolating valves will put any other part of the system or personnel at risk. Dangers might include; isolation of vents and protective devices or alarms. Ensure isolation valves are turned off in a gradual way to avoid system shocks.

Pressure

Before attempting any maintenance consider what is or may have been in the pipeline. Ensure that any pressure is isolated and safely vented to atmospheric pressure before attempting to maintain the product, this is easily achieved by fitting Spirax Sarco depressurisation valves type DV (see separate literature for details). Do not assume that the system is depressurised even when a pressure gauge indicates zero.

Temperature

Allow time for temperature to normalise after isolation to avoid the danger of burns and consider whether protective clothing (including safety glasses) is required.

Viton seat:

If the Viton seat has been subjected to a temperature approaching 315°C (599°F) or higher it may have decomposed and formed hydrofluoric acid. Avoid skin contact and inhalation of any fumes as the acid will cause deep skin burns and damage the respiratory system.

Disposal

These products are recyclable. No ecological hazard is anticipated with the disposal of these products providing due care is taken, EXCEPT:

Viton seat:

- Waste parts can be landfilled, when in compliance with National and Local regulations.
- Parts can be incinerated, but a scrubber must be used to remove Hydrogen Fluoride, which is evolved from the product and with compliance to National and Local regulations.
- Parts are insoluble in aquatic media.

— 2. General product information —

2.1 General description

The DCV1, DCV2 and DCV3 disc check valves are of the wafer pattern designed to be sandwiched between flanges. They are suitable for use on a wide range of fluids for applications in process lines, hot water systems, steam and condensate systems etc. Face-to-face dimensions conform to EN 558 part 1, series 49.

As standard the valves have a metal-to-metal seat. See Section 2.5 for other options which are available on request.

Note: For additional information see Technical Information Sheets; TI-P134-05 for the DCV1 or TI-P134-50 for the DCV2 and DCV3.

2.2 Sizes and pipe connections

DN15, 20, 25, 32, 40, 50, 65, 80 and 100

Suitable for installation between BS 10 Tables 'E' and 'H'.

BS 4504/(DIN) PN6, 10, 16, 25, 40;

JIS 5, 10, 16 and 20 flanges with the following exceptions:-

DN40, 50, 80 and 100 - will not fit between JIS 5 flanges

DN65 and 80 - will not fit between BS 10 'E' flanges.

2.3 Optional extras

Heavy duty springs (700 mbar [10 psi] opening pressure up to DN65) for boiler feed applications.

Viton soft seats for oil, gas and steam applications.

EPDM soft seats for water applications.

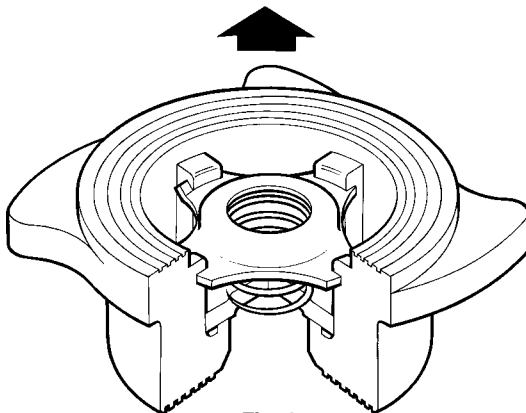

Fig. 1
DCV1, DCV2 and DCV3

2.4 Materials

| Part | | Material |
|-------------------------|------|----------------------------|
| Body | DCV1 | Bronze |
| | DCV2 | Ferritic stainless steel |
| | DCV3 | Austenitic stainless steel |
| Disc | | Austenitic stainless steel |
| Spring retainer | | Austenitic stainless steel |
| Standard spring | | Austenitic stainless steel |
| Heavy duty spring | | Austenitic stainless steel |
| High temperature spring | | Nickel alloy |

2.5 Seating options

The valves are stamped to identify the internals fitted:

| | | |
|------|---|-------------------|
| 'N' | - High temperature spring | - Metal disc seat |
| 'H' | - Heavy duty spring | - Metal disc seat |
| 'W' | - Without spring | - Metal disc seat |
| 'V' | - Standard spring | - Viton disc seat |
| 'E' | - Standard spring | - EPDM disc seat |
| 'WV' | - Without spring | - Viton disc seat |
| 'WE' | - Without spring | - EPDM disc seat |
| 'HV' | - Heavy duty spring | - Viton disc seat |
| 'HE' | - Heavy duty spring | - EPDM disc seat |
| 'T' | - Valves tested to DIN 3230 part 3, B03 | |

No identification indicates a standard spring with a metal disc.

2.6 Limiting conditions and operating ranges

Note: Special testing to allow lower temperature operation can be provided at extra cost. Consult Spirax Sarco.

DCV1

| | | |
|---|------------|----------------------------------|
| Body design conditions | PN16 | |
| PMO - Maximum operating pressure | 16 bar g | (232 psi g) |
| TMO - Maximum operating temperature | 260°C | (500°F) |
| Minimum operating temperature | -198°C | (-324°F) |
| Temperature limits | Viton seat | -15°C to +250°C (5°F to 482°F) |
| | EPDM seat | -50°C to +150°C (-58°F to 302°F) |
| Designed for a maximum cold hydraulic test pressure of: | 24 bar g | (348 psi g) |

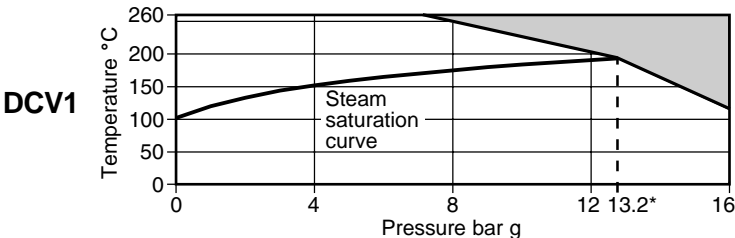

 The product must not be used in this region.

* PMO Maximum operating pressure when used for steam service.

DCV2

| | | | |
|---|-------------------------|-----------------|------------------|
| Body design conditions | | PN40 | |
| PMO - Maximum operating pressure | | 40 bar g | (580 psi g) |
| TMO - Maximum operating temperature | Standard spring | 300°C | (572°F) |
| | Heavy duty spring | 300°C | (572°F) |
| | High temperature spring | - | - |
| | Without spring | 300°C | (572°F) |
| Minimum operating temperature (standard disc) | | -60°C | (-76°F) |
| Temperature limits | Viton seat | -15°C to +250°C | (5°F to 482°F) |
| | EPDM seat | -50°C to +150°C | (-58°F to 302°F) |
| Designed for a maximum cold hydraulic test pressure of: | | 60 bar g | (870 psi g) |

DCV3

| | | | |
|---|-------------------------|-----------------|-----------------|
| Body design conditions | | PN40 | |
| PMO - Maximum operating pressure | | 40 bar g | (580 psi g) |
| TMO - Maximum operating temperature | Standard spring | 300°C | (572°F) |
| | Heavy duty spring | 300°C | (572°F) |
| | High temperature spring | 400°C | (752°F) |
| | Without spring | 400°C | (752°F) |
| Minimum operating temperature (standard disc) | | -10°C | (14°F) |
| Temperature limits | Viton seat | -10°C to +250°C | (14°F to 482°F) |
| | EPDM seat | -10°C to +150°C | (14°F to 302°F) |
| Designed for a maximum cold hydraulic test pressure of: | | 60 bar g | (870 psi g) |

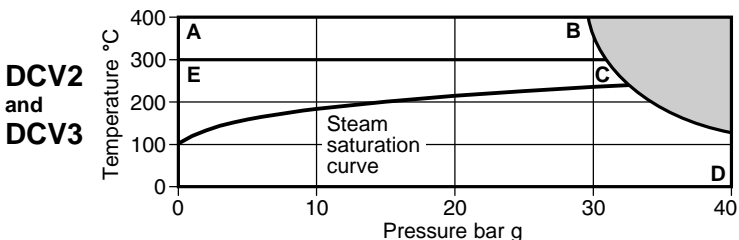

 The product must not be used in this region.

E - C - D DCV2 and DCV3 with standard spring.

A - B - D DCV3 High temperature spring and without spring.

3. Installation

Note: Before actioning any installation observe the 'Safety information' in Section 1.

Referring to the Installation and Maintenance Instructions, name-plate and Technical Information Sheet, check that the product is suitable for the intended installation:

- 3.1** Check materials, pressure and temperature and their maximum values. If the maximum operating limit of the product is lower than that of the system in which it is being fitted, ensure that a safety device is included in the system to prevent overpressurisation.
- 3.2** Determine the correct installation situation and the direction of fluid flow.
- 3.3** Remove protective covers from all connections.
- 3.4** Valves must only be installed where 'weld neck' flanges are used. Other flange types may restrict operation.
- 3.5** Disc check valves simply fit between two pipe flanges (see Fig. 2). Standard gaskets are used either side of the valve together with longer bolts or studs. **Note:** flanges, bolts (or studs), nuts and joint gaskets to be provided by the installer. Normal sensible flange bolting practice should be followed eg. torque tightening the bolts in opposite sequence.
- 3.6** The DCV1, DCV2 and DCV3 can be installed in any plane with the exception of DCV's supplied without an internal spring. These must be fitted in a vertical flow line with the flow from bottom-to-top i.e. upward flow (see Fig. 2b). Disc check valves must be fitted in accordance with the direction of the flow arrow on the body, indicating correct fluid flow direction.

Note: Disc check valves are not suitable for use where heavily pulsating flow exists, such as close to a compressor.

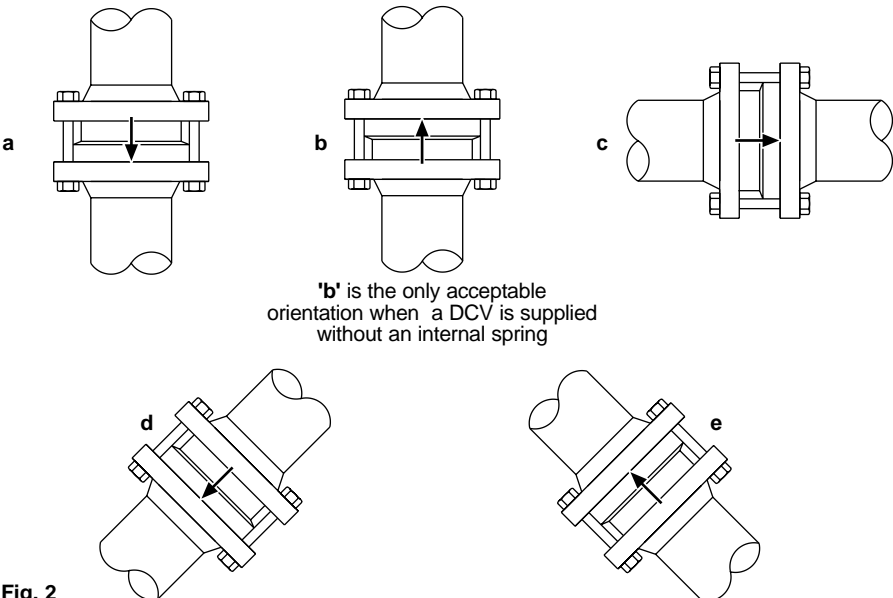

Fig. 2

4. Commissioning

After installation or maintenance ensure that the system is fully functional. Carry out tests on any alarms or protective devices.

5. Operation

Disc check valves are opened by the pressure of the fluid and closed by the spring as soon as the flow ceases and before the reverse flow occurs.

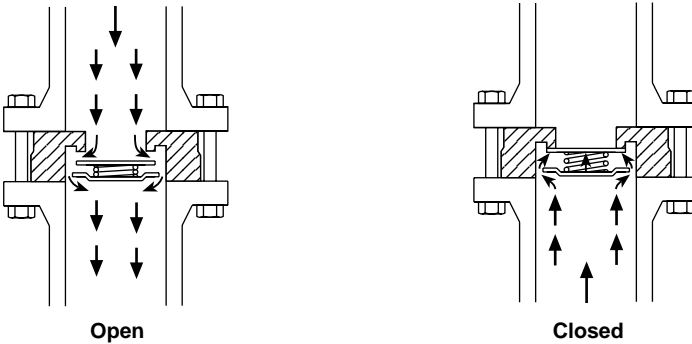

Fig. 3

Open

Closed

K_V values

| Size | DN15 | DN20 | DN25 | DN32 | DN40 | DN50 | DN65 | DN80 | DN100 |
|----------------|------|------|------|------|------|------|------|------|-------|
| K _V | 4.4 | 6.8 | 10.8 | 17 | 26 | 43 | 60 | 80 | 113 |

For conversion C_V (UK) = K_V x 0.97 C_V (US) = K_V x 1.17

Opening pressures in mbar

Differential pressures with zero flow for standard and high temperature springs.

→ Flow direction

| Direction | DN15 | DN20 | DN25 | DN32 | DN40 | DN50 | DN65 | DN80 | DN100 |
|-----------|------|------|------|------|------|------|------|------|-------|
| ↑ | 25 | 25 | 25 | 27 | 28 | 29 | 30 | 31 | 33 |
| → | 22.5 | 22.5 | 22.5 | 23.5 | 24.5 | 24.5 | 25 | 25.5 | 26.5 |
| ↓ | 20 | 20 | 20 | 20 | 20 | 20 | 20 | 20 | 20 |

Where lowest opening pressures are required, valves without springs can be installed in vertical pipes with bottom-to-top flow.

Without spring

| | | | | | | | | | |
|---|-----|-----|-----|-----|-----|-----|-----|-----|-----|
| ↑ | 2.5 | 2.5 | 2.5 | 3.5 | 4.0 | 4.5 | 5.0 | 5.5 | 6.5 |
|---|-----|-----|-----|-----|-----|-----|-----|-----|-----|

Heavy duty springs approximately 700 mbar

6. Maintenance

Note: Before actioning any maintenance programme observe the 'Safety information' in Section 1.

This product is non-maintainable.

Note: Great care must be taken if a DCV with a heavy duty spring is taken apart since the strength of the spring can cause the retainer to spring out of the body.

7. Spare parts

There are no spare parts available for this product.

How to order a new product

Example:

1 off Spirax Sarco DN25, DCV2 ferritic stainless steel disc check valve for fitting between DN25, PN40 flanges.