

Self-acting temperature controls

with 2-port valves



spirax
/sarco

Self-acting controls, the simplest and most reliable solution for controlling temperature

Environment

Some of the environments most likely to require self-acting temperature controls are:-

- Explosive areas
- External exposure
- Acid atmospheres
- Shipboard
- Wet areas
- Dirty areas
- Power free locations
- Underground

Gunmetal, cast iron and cast carbon steel valves for heating and cooling

Accuracy

Self-acting controls give stable, modulating control within close tolerances. On storage and constant load applications they will control at set value. On variable load applications they will normally operate within a very narrow temperature band.

Reliability

Because our control systems operate through liquid expansion with friction-free bellows, they have a long maintenance-free life with repeatable performance.

Bellows valve stem seals

Easy to use

'Set and forget' is the normal method of using self-acting controls. Even where temperature settings must vary, operators find them quick and simple to operate.

Easy to install

Self-acting temperature controls are a one-trade mechanical installation. The uncomplicated construction and small number of components makes them easy to understand so that installation is straightforward.

6 control system types controlling temperatures from -15°C to +170°C



Easy to commission

Normally the operator or fitter sets the required temperature and that's it. Some installations call for a few minutes re-setting otherwise, 'set and forget'.

Valve range

For heating		
Body material	Screwed	Flanged
Gunmetal	DN15 - DN80	DN65 - DN80
Cast iron	DN15 - DN50	DN15 - DN50
Cast carbon steel		DN15 - DN50

For cooling		
Body material	Screwed	Flanged
Gunmetal	DN15 - DN80	DN65 - DN80
Cast iron	DN15 - DN50	DN15 - DN50
Cast carbon steel		DN15 - DN50

Principles of operation

A change in temperature at the sensor will cause the liquid filling to expand or contract. If the liquid expands it will apply a force on the thrust pin which, in turn, will cause the valve plug to move. As the liquid contracts the force on the valve plug reduces and a spring reverses its direction of travel.

For heating applications the valves will be normally open and will close against a rise in temperature.

For cooling applications the valves will be normally closed and will open against a rise in temperature.

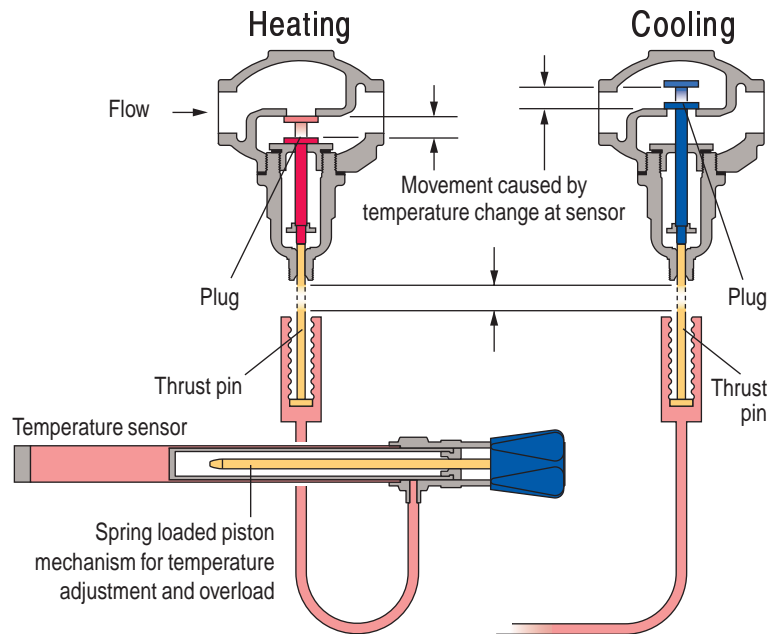

Option of dial or tamper proof knob adjustment mechanism.

Plastic coated copper capillaries with armoured covering. Standard lengths of 2 m, 4 m, 8 m and 20 m all available from stock

User benefits

- Low capital and installation cost - one-trade installation.
- Accurate and reliable - for years of trouble free service.
- Virtually maintenance free.
- Intrinsically safe operation.
- Simple to commission.
- Free from electrical or pneumatic breakdown.
- No expensive safety checks.

Typical heating applications

Hot water storage

One of the most popular applications for self-acting control is hot water service where control valve (1) maintains a constant hot water temperature and control valve (2) provides protection against excess temperature*. The benefits of one-trade fix, value for money and 365 days per year reliability, make self-acting temperature controls a strong contender for this type of application.

* See back page.

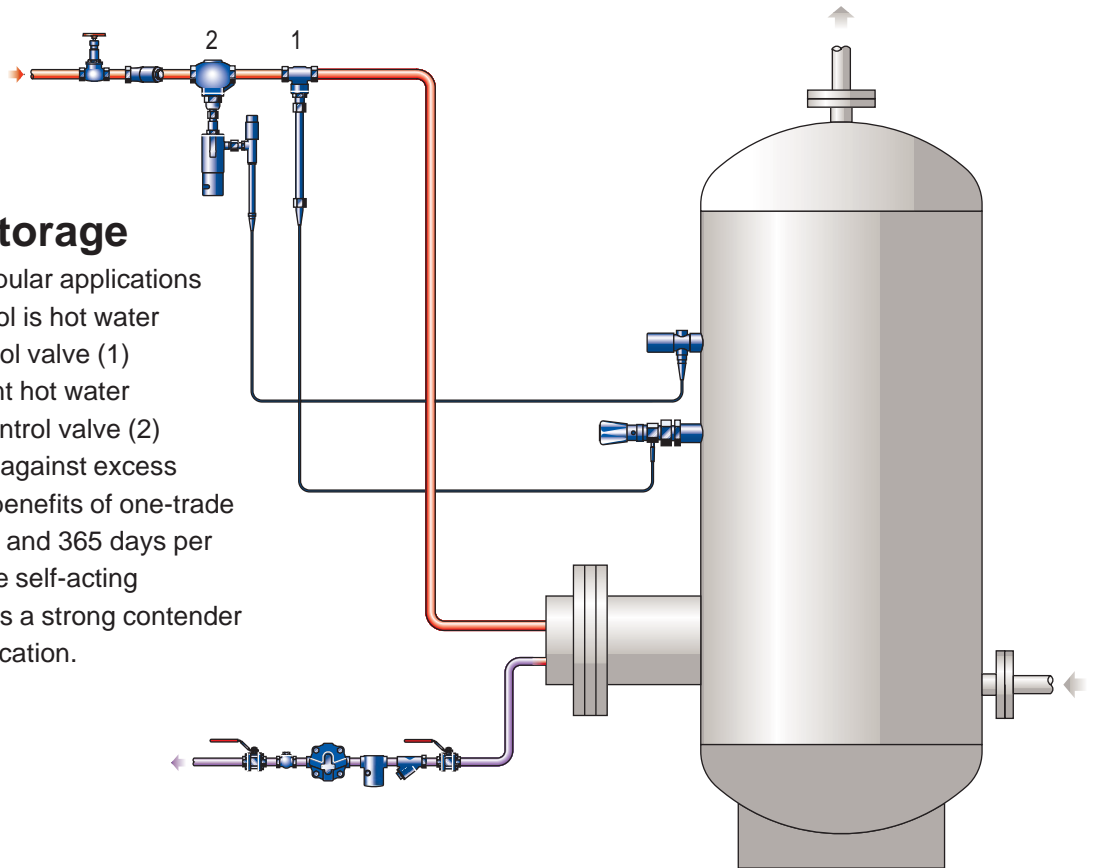

Plating tanks

Where products are exposed to poor environmental conditions, noxious spillage or where the operator must re-set the control temperature with changing batches, then self-acting controls provide close control coupled with safety, ease of use and robustness.

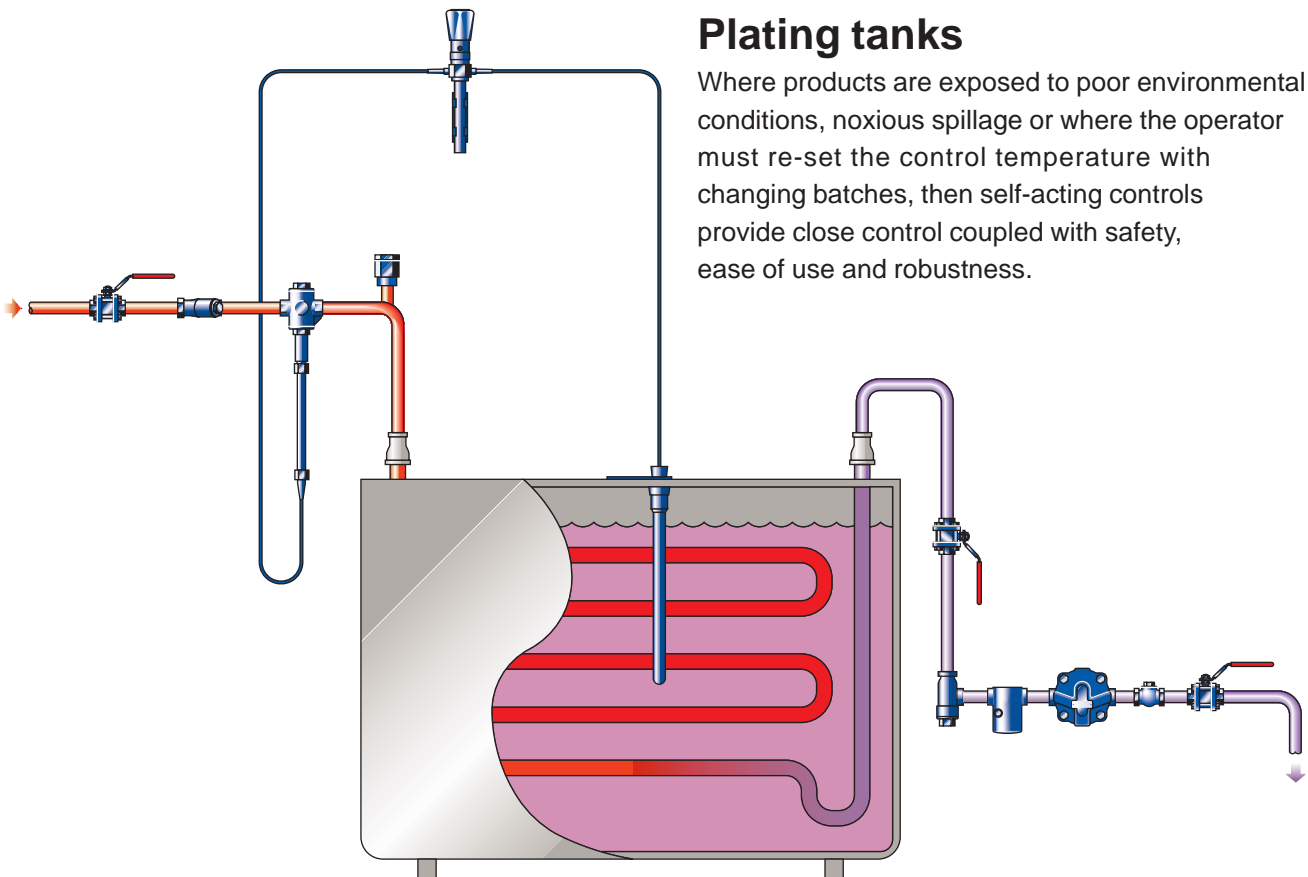

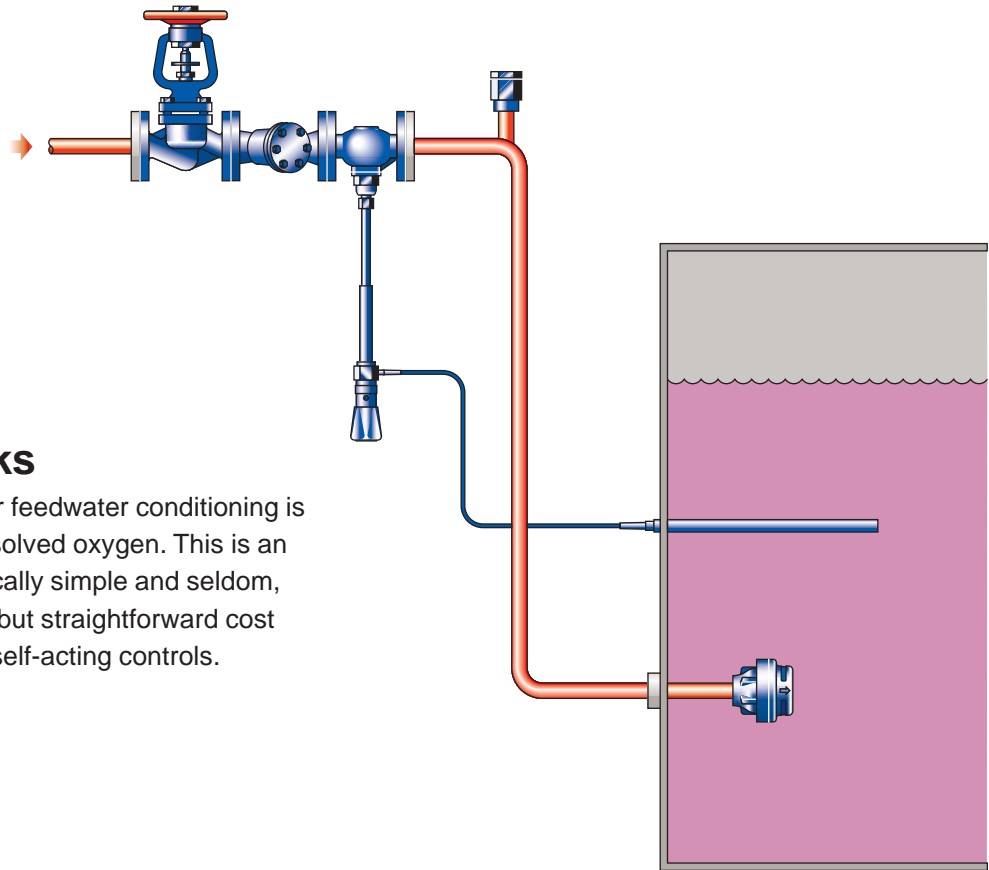

Boiler feedtanks

An essential part of boiler feedwater conditioning is the need to drive out dissolved oxygen. This is an application which is basically simple and seldom, if ever, calls for anything but straightforward cost effective 'set and forget' self-acting controls.

Typical cooling application

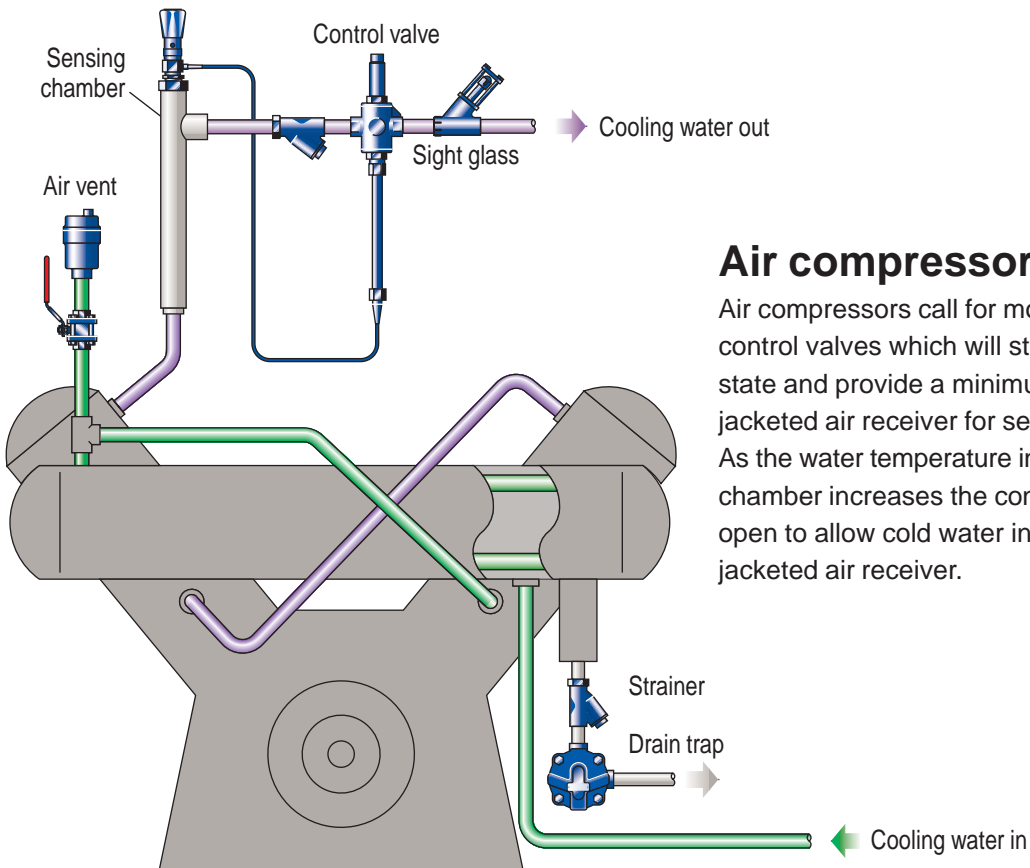

Air compressor cooling

Air compressors call for modulating temperature control valves which will start up in the closed state and provide a minimum bleed through the jacketed air receiver for sensing purposes. As the water temperature in the sensing chamber increases the control valve will open to allow cold water into the jacketed air receiver.

How to select a system

Valve selection

- 1 Is the application for heating or cooling?
A heating application will require a valve that is normally open and will close with rising temperature. A cooling application will require a valve that is normally closed and will open with rising temperature.
- 2 Is the valve to be used on steam or water?
For steam the sizing table on page 7 is used and for water the table on page 8 is used.
- 3 Determine the pressure upstream of the valve (P_1) for normal running conditions.
- 4 Determine the pressure downstream of the valve (P_2) for normal running conditions.
- 5 Determine the required flowrate of steam or water.
- 6 Determine the size and basic type of valve using the sizing charts on pages 7 and 8. A sizing example is shown on each of these pages.

At this point only the valve size and basic valve type has been selected. It is now necessary to refer to pages 10 and 11 to check the following:

- 7 What body material is required?
Pressure temperature limitations for each material (gunmetal, cast iron and cast carbon steel) are shown in table 3. Economics may also influence the choice of body material.
- 8 What end connections are required - screwed or flanged? Choices are shown in tables 1 and 2.
- 9 Normally closed valves may have a bleed which allows a small flow to reach the sensor so that it can react to a temperature rise. This will be dependent on the application.
- 10 What is the maximum differential pressure across the valve? In a heating application with a normally open valve a rise in temperature at the sensor will cause the valve to close. In order to ensure that the valve closes fully the sensor must be able to overcome the force generated on the valve plug by the maximum differential pressure across the valve ($P_{1 \text{ max}} - P_{2 \text{ min}}$). This is often substantially greater than the normal running pressure drop across the valve. Similarly with a normally closed valve, the return spring must be able to close it against the maximum differential pressure. The maximum differential pressure for each valve is shown in tables 1 and 2 on pages 10 and 11. The maximum differential pressure of a valve may be increased by incorporating a balancing bellows, details of which are also indicated in tables 1 and 2.

Control system selection

The control system consists of the sensor, capillary tube and actuator. Tables on pages 10 and 11 show which control systems are compatible with each valve:

- 11 From table 5 on page 13, select a temperature range which allows adjustment on both sides of the control point.
- 12 Choose the configuration of the control system to suit the application.
- 13 Choose the length of capillary tube.
- 14 Choose any ancillaries (pockets, mounting brackets etc.) from page 14.

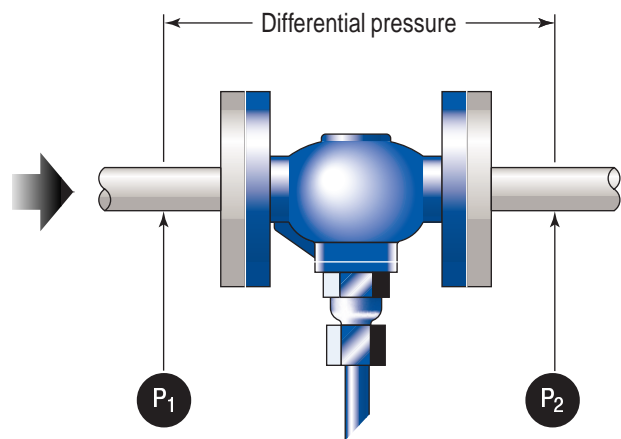

Note: pressures for sizing charts are in bar g

Typical order information

Spirax Sarco self-acting temperature control comprising:

DN20 KA43 control valve flanged PN40,

SA121 control system, range 2,

2 m capillary tube length,

stainless steel pocket.

Valve sizing for steam

Heating

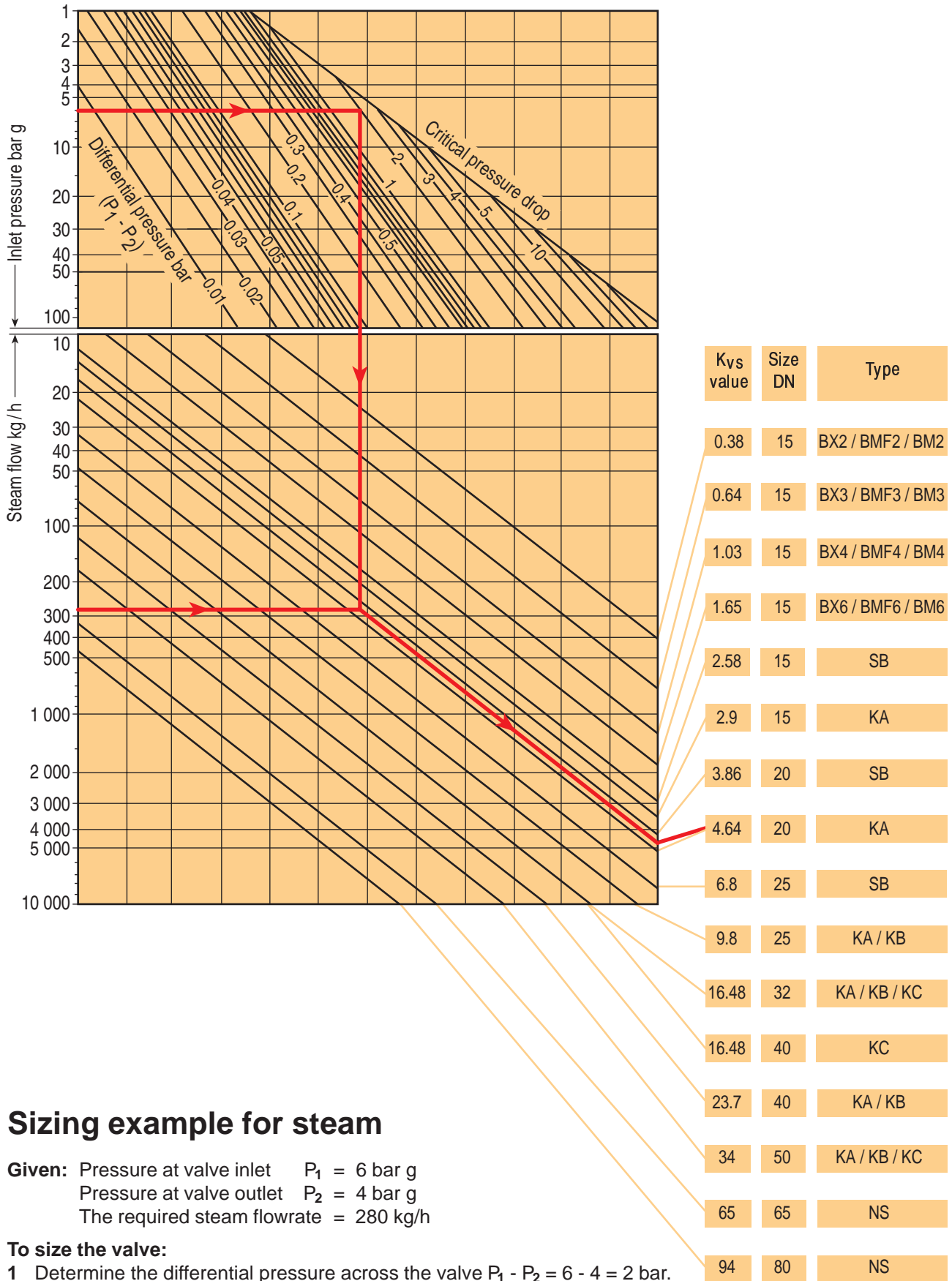

Sizing example for steam

Given: Pressure at valve inlet $P_1 = 6$ bar g
 Pressure at valve outlet $P_2 = 4$ bar g
 The required steam flowrate = 280 kg/h

To size the valve:

- 1 Determine the differential pressure across the valve $P_1 - P_2 = 6 - 4 = 2$ bar.
- 2 Enter the upper section of the chart with the inlet pressure (P_1) at 6 bar g and draw horizontal line to intersect the differential pressure ($P_1 - P_2$) line at 2 bar. From this intersection draw a vertical line downwards.
- 3 Enter the lower section of the chart with the steam flowrate at 280 kg/h and draw a horizontal line to intersect the vertical line produced in step 2. From this intersection draw a line parallel to the diagonal lines in the direction of the valve selection box.
- 4 From the valve selection boxes choose the valve with the higher K_{VS} value i.e. size DN20 'K' type valve.

Valve sizing for water

Heating

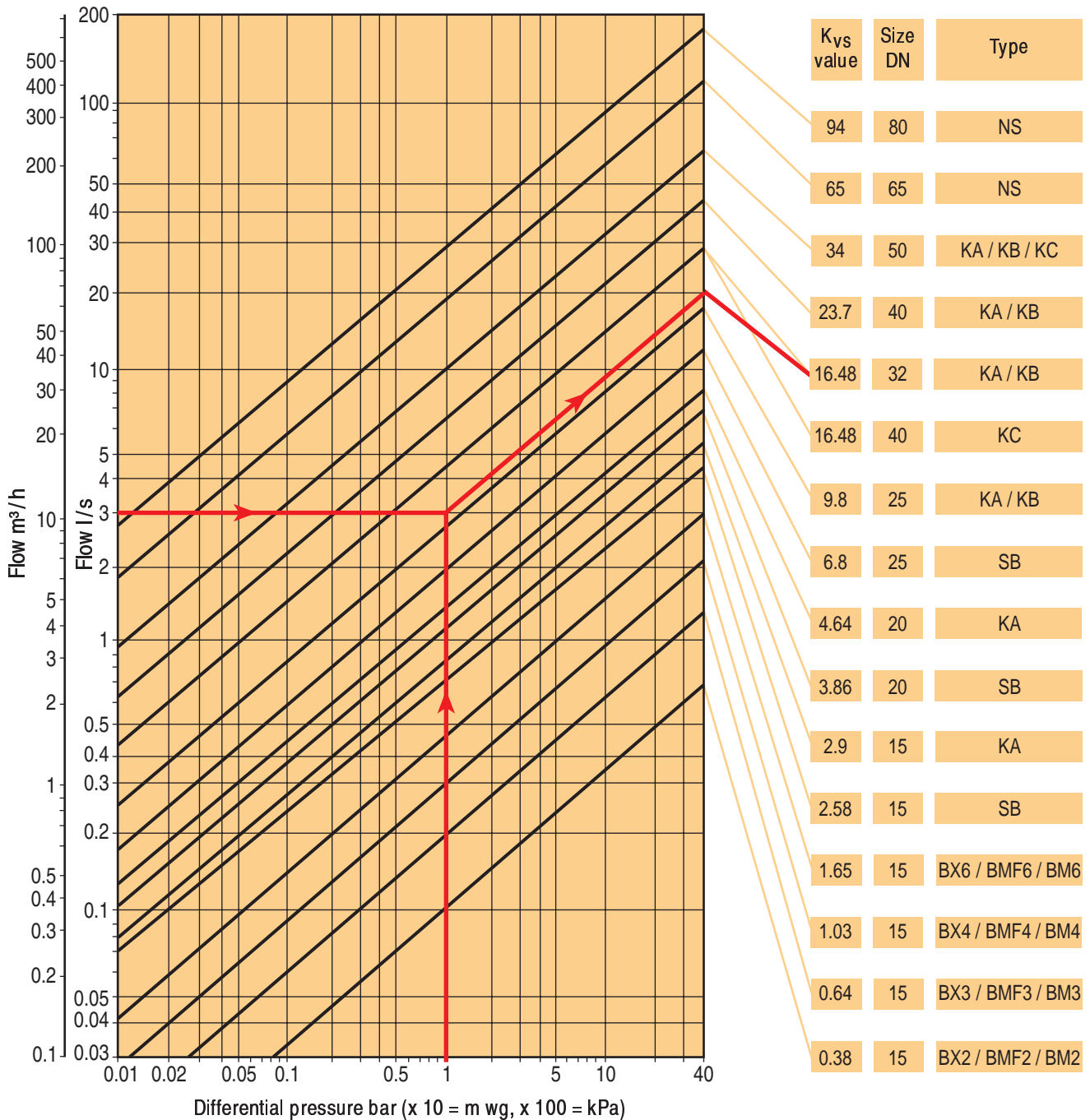

Sizing example for water

Given: Pressure at valve inlet $P_1 = 14 \text{ bar g}$
 Pressure at valve outlet $P_2 = 13 \text{ bar g}$
 The required water flowrate = 3 litres/second

To size the valve:

- Determine the differential pressure across the valve $P_1 - P_2 = 14 - 13 = 1 \text{ bar}$
- Enter the top chart (for heating applications) bottom chart (for cooling applications) with a flowrate of 3 litres/second and draw a horizontal line to intersect the differential pressure line at 1 bar.
 From this intersection draw a line parallel to the diagonal lines in the direction of the valve selection boxes.
- From the valve selection boxes choose the valve with the higher K_{vs} value i.e. size DN32 'K' type valve.

Valve sizing for water

Cooling

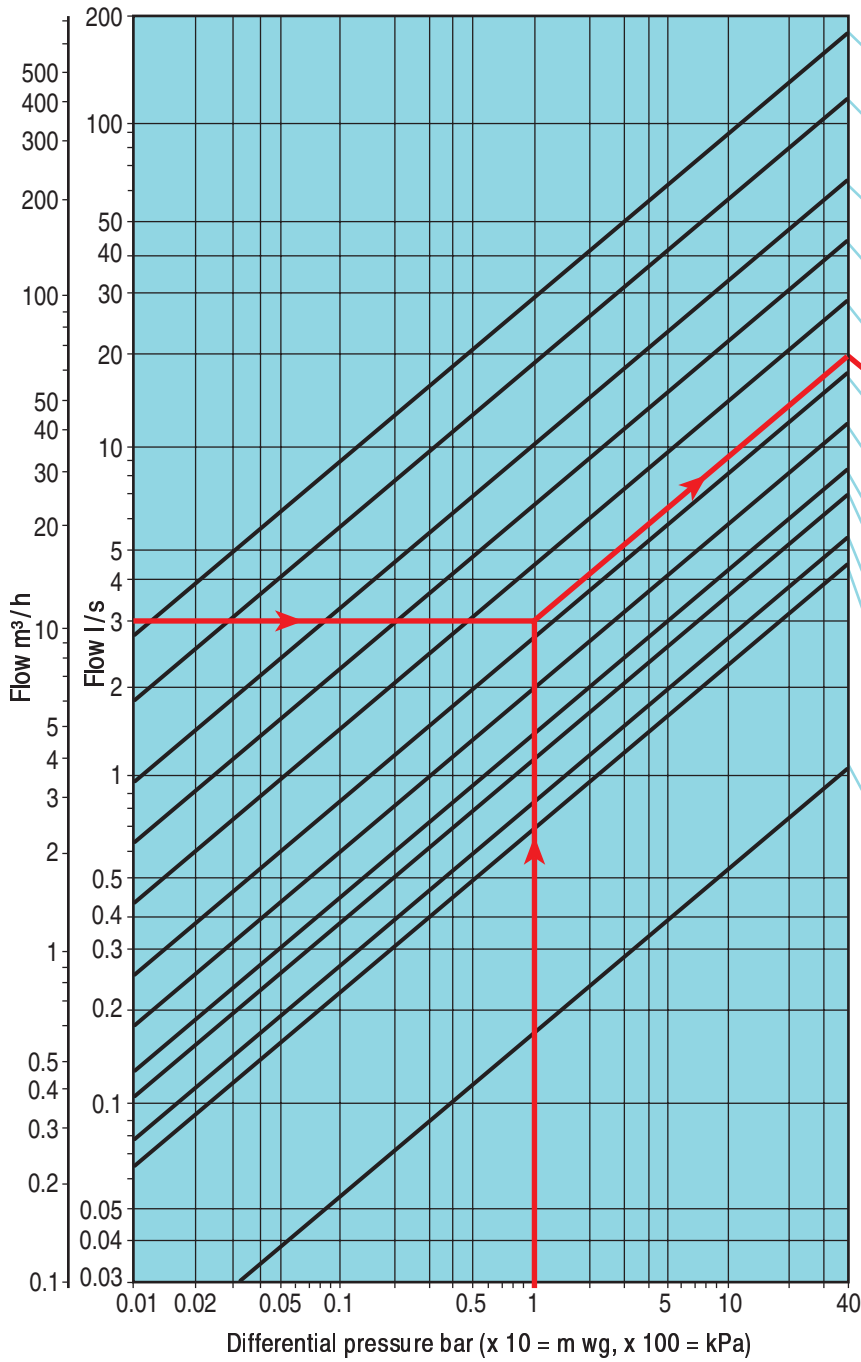

K_{vs} value	Size DN	Type
94	80	NSRA
65	65	NSRA
34	50	KX / KY
23.7	40	KX / KY
16.48	32	KX / KY
9.8	25	KX
6.8	25	SBRA
4.64	20	KX
3.86	20	SBRA
2.9	15	KX
2.58	15	SBRA
0.59	15	BXRA / BMFRA / BMRA

Valve selection data

Table 1 - Normally open valves for heating applications

Valve model	Size DN	Connections					Kvs	Maximum ΔP (bar)	Control system options							
		Screwed		Flanged		Bal- anced			SA121	SA122	SA123	SA128	Type 422	SA423		
		BSP	NPT	PN	ANSI											
Gunmetal																
BX 2	15	•	•				0.38	17.2	•	•	•	•	•	•	•	
		•	•				0.64	17.2	•	•	•	•	•	•	•	
		•	•				1.03	17.2	•	•	•	•	•	•	•	•
		•	•				1.65	17.2	•	•	•	•	•	•	•	•
SB	15	•	•				2.58	17.2	•	•	•	•	•	•	•	
	20	•	•				3.86	10.3	•	•	•	•	•	•	•	
	25	•	•				6.80	6.8	•	•	•	•	•	•	•	
KA51	25	•	•				9.80	4.5	•	•	•	•	•	•	•	
	32	•	•				16.48	3.0	•	•	•	•	•	•	•	
	40	•	•				23.70	2.0	•	•	•	•	•	•	•	
	50	•	•				34.00	1.5	•	•	•	•	•	•	•	
KB51 Balanced by phosphor bronze bellows	25	•	•			•	9.80	10.0	•	•	•	•	•	•	•	
	32	•	•			•	16.48	9.0	•	•	•	•	•	•	•	
	40	•	•			•	23.70	8.2	•	•	•	•	•	•	•	
	50	•	•			•	34.00	6.9	•	•	•	•	•	•	•	
KC51 Balanced by stainless steel bellows	40	•	•			•	16.48	16.0	•	•	•	•	•	•	•	
	50	•	•			•	34.00	13.8	•	•	•	•	•	•	•	
NS double sealed valve	65	•	•	25	150		65.00	10.0	•	•	•	•	•	•	•	
	80	•	•	25	150		94.00	10.0	•	•	•	•	•	•	•	
Cast iron																
BMF 2	15			16			0.38	16.0	•	•	•	•	•	•	•	
				16			0.64	16.0	•	•	•	•	•	•	•	
				16			1.03	16.0	•	•	•	•	•	•	•	
				16			1.65	16.0	•	•	•	•	•	•	•	
KA31	15	•	•				2.90	13.0	•	•	•	•	•	•	•	
	20	•	•				4.64	10.3	•	•	•	•	•	•	•	
	25	•	•				9.80	4.5	•	•	•	•	•	•	•	
	32	•	•				16.48	3.0	•	•	•	•	•	•	•	
	40	•	•				23.70	2.0	•	•	•	•	•	•	•	
	50	•	•				34.00	1.5	•	•	•	•	•	•	•	
KA33	15			16			2.90	13.0	•	•	•	•	•	•	•	
	20			16			4.64	10.3	•	•	•	•	•	•	•	
	25			16			9.80	4.5	•	•	•	•	•	•	•	
	32			16			16.48	3.0	•	•	•	•	•	•	•	
	40			16			23.70	2.0	•	•	•	•	•	•	•	
	50			16			34.00	1.5	•	•	•	•	•	•	•	
KB31 Balanced by phosphor bronze bellows	25	•	•			•	9.80	10.3	•	•	•	•	•	•	•	
	32	•	•			•	16.48	9.0	•	•	•	•	•	•	•	
	40	•	•			•	23.70	8.2	•	•	•	•	•	•	•	
	50	•	•			•	34.00	6.9	•	•	•	•	•	•	•	
KB33 Balanced by phosphor bronze bellows	25			16		•	9.80	10.3	•	•	•	•	•	•	•	
	32			16		•	16.48	9.0	•	•	•	•	•	•	•	
	40			16		•	23.70	8.2	•	•	•	•	•	•	•	
	50			16		•	34.00	6.9	•	•	•	•	•	•	•	
KC31 Balanced by stainless steel bellows	40			16		•	16.48	13.0	•	•	•	•	•	•	•	
	50			16		•	34.00	13.0	•	•	•	•	•	•	•	

For pressure temperature relationships please refer to operating charts on page 16.

Table 1 - Normally open valves for heating applications

Valve model	Size DN	Connections				Bal-anced	Kvs	Maximum ΔP (bar)	Control system options						
		Screwed BSP	NPT	Flanged PN	ANSI				SA121	SA122	SA123	SA128	Type 422	SA423	
Cast carbon steel															
BMF 2	15			25	300		0.38	17.2	•	•	•	•	•	•	
3				25	300		0.64	17.2	•	•	•	•	•	•	
4				25	300		1.03	17.2	•	•	•	•	•	•	
6				25	300		1.65	17.2	•	•	•	•	•	•	
KA43	15			40	300		2.90	17.0	•	•	•	•	•	•	
	20			40	300		4.64	10.0	•	•	•	•	•	•	
	25			40	300		9.80	4.5	•	•	•	•	•	•	
	32			40	300		16.48	3.0	•	•	•	•	•	•	
	40			40	300		23.70	2.0	•	•	•	•	•	•	
KB43	25			40	300	•	9.80	10.0	•	•	•	•	•	•	
	32			40	300	•	16.48	9.0	•	•	•	•	•	•	
	40			40	300	•	23.70	8.2	•	•	•	•	•	•	
	Balanced by phosphor bronze bellows	50			40	300	•	34.00	6.9	•	•	•	•	•	•
KC43	32			40	300	•	16.48	16.0	•	•	•	•	•	•	
	40			40	300	•	16.48	16.0	•	•	•	•	•	•	
	50			40	300	•	34.00	13.8	•	•	•	•	•	•	

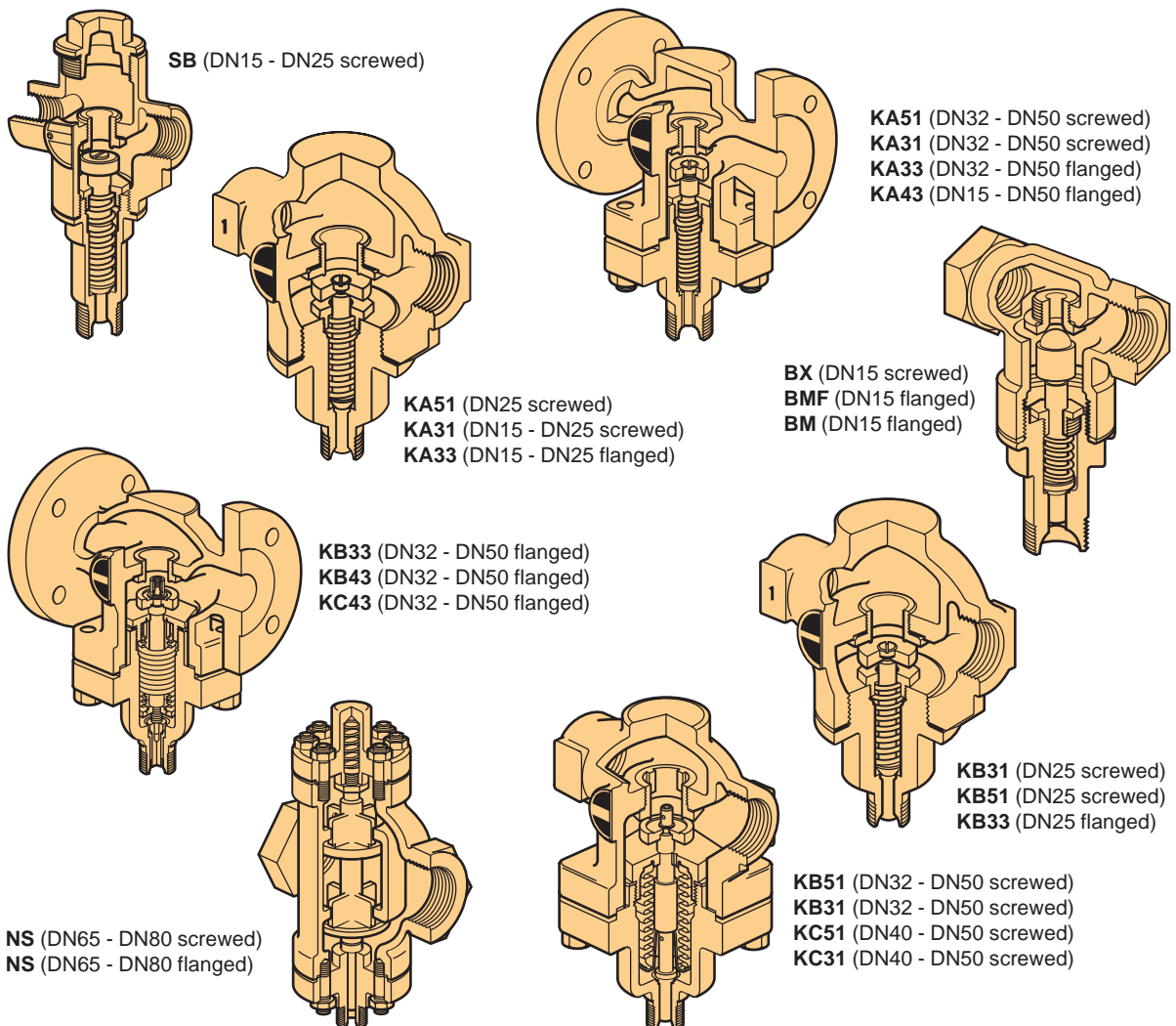

Valve selection data

Table 2 - Normally closed valves for cooling applications

Valve model	Size DN	Connections					Kvs	Maximum ΔP (bar)	Control system options					
		Screwed		Flanged		Bal- anced			SA121	SA122	SA123	SA128	Type 422	SA423
		BSP	NPT	PN	ANSI									
Gunmetal														
BXRA	15	•	•				0.59	10.3	•	•	•	•	•	•
SBRA	15	•	•				2.58	12.0	•	•	•	•	•	•
Optional bleed available	20	•	•				3.86	7.0	•	•	•	•	•	•
	25	•	•				6.80	4.7	•	•	•	•	•	•
NSRA Double seated valve	65	•	•	25	150		65.00	2.7	•		•		•	•
	80	•	•	25	150		94.00	2.0	•		•		•	•
KX51	25	•	•				9.80	3.5	•	•	•	•	•	•
Optional bleed available	32	•	•				16.48	2.3	•		•		•	•
	40	•	•				23.70	1.7	•		•		•	•
	50	•	•				34.00	1.1	•		•		•	•
KY51 Balanced by phosphor bronze bellows. Optional bleed available	32	•	•			•	16.48	9.0	•		•		•	•
	40	•	•			•	23.70	8.2	•		•		•	•
	50	•	•			•	34.00	6.9	•		•		•	•
Cast iron														
BMFRA	15	•	•				0.59	10.3	•	•	•	•	•	•
KX31	15	•	•				2.90	12.0	•	•	•	•	•	•
Optional bleed available	20	•	•				4.64	7.0	•	•	•	•	•	•
	25	•	•				9.80	3.5	•	•	•	•	•	•
	32	•	•				16.48	2.3	•		•		•	•
	40	•	•				23.70	1.7	•		•		•	•
	50	•	•				34.00	1.1	•		•		•	•
KX33 Optional bleed available	15			16			2.90	12.0	•	•	•	•	•	•
	20			16			4.64	7.0	•	•	•	•	•	•
	25			16			9.80	3.5	•	•	•	•	•	•
	32			16			16.48	2.3	•		•		•	•
	40			16			23.70	1.7	•		•		•	•
50			16			34.00	1.1	•		•		•	•	
KY31 Balanced by phosphor bronze bellows. Optional bleed available.	32	•	•			•	16.48	9.0	•		•		•	•
	40	•	•			•	23.70	8.2	•		•		•	•
	50	•	•			•	34.00	6.9	•		•		•	•
KY33 Balanced by phosphor bronze bellows. Optional bleed available.	32			16		•	16.48	9.0	•		•		•	•
	40			16		•	23.70	8.2	•		•		•	•
	50			16		•	34.00	6.9	•		•		•	•

For pressure temperature relationships please refer to operating charts on page 16.

Table 2 - Normally closed valves for cooling applications

Valve model	Size DN	Connections				K _{vs}	Maximum ΔP (bar)	Control system options					
		Screwed		Flanged				SA121	SA122	SA123	SA128	Type 422	SA423
		BSP	NPT	PN	ANSI								
Cast carbon steel													
BMRA	15			25		0.59	10.3	•	•	•	•	•	•
KX43	15			40		2.90	12.0	•	•	•	•	•	•
Optional bleed available	20			40		4.64	7.0	•	•	•	•	•	•
	25			40		9.80	3.5	•	•	•	•	•	•
	32			40		16.48	2.3	•	•	•	•	•	•
	40			40		23.70	1.7	•	•	•	•	•	•
	50			40		34.00	1.1	•	•	•	•	•	•
KY43 Balanced by phosphor bronze bellows. Optional bleed available.	32			40		•	16.48	9.0	•		•	•	•
	40			40		•	23.70	8.2	•		•	•	•
	50			40		•	34.00	6.9	•		•	•	•

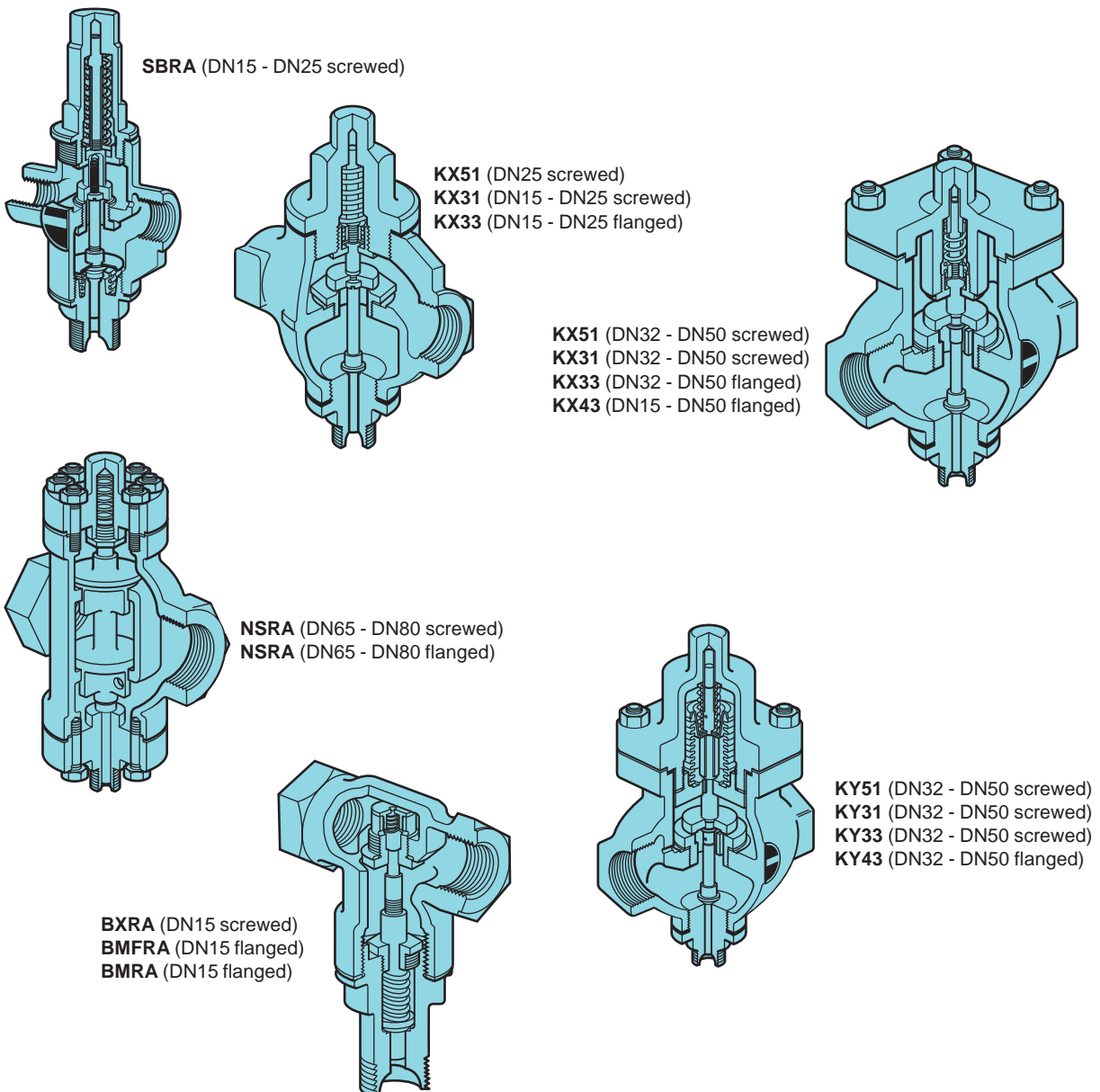

Dimensions (approximate in mm)

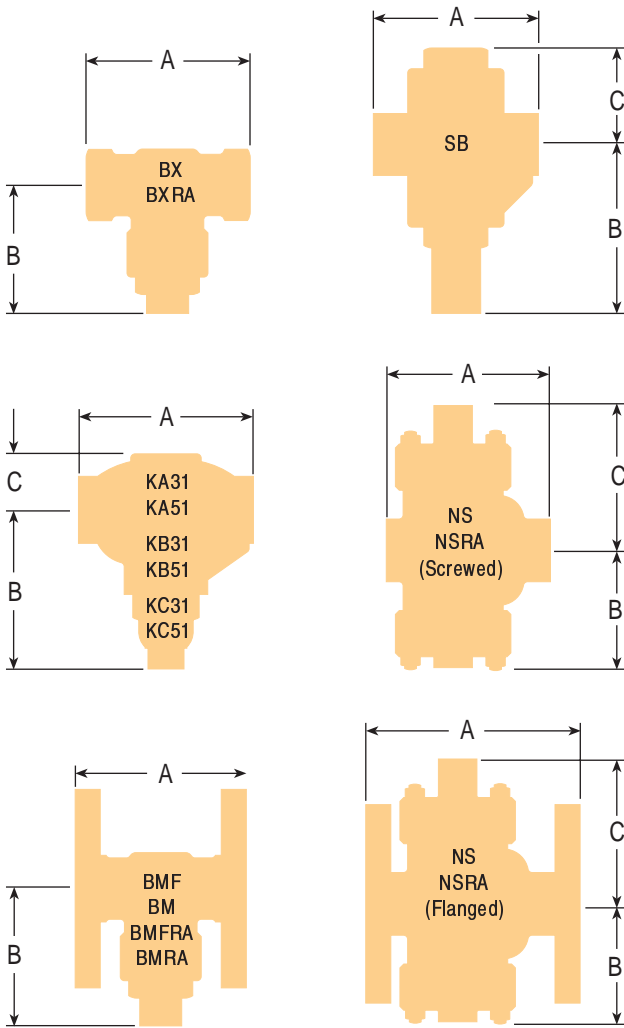

Valve model	Size DN	BSP NPT A	PN 16 A	PN 25 / 40 A	ANSI *150 300 A	B	C	Weight kg	
								Scrd	Flgd

Cast iron

BMF	15		130			87			3.6
KA31	15	90				105	37	1.30	
	20	104				105	37	1.60	
	25	136				107	51	3.20	
	32	144				110	51	5.10	
	40	150				110	62	6.30	
	50	180				110	71	7.80	
KA33	15		130			105	37		3.3
	20		150			105	37		4.3
	25		160			107	51		5.7
	32		180			110	51		8.8
	40		200			110	62		11.0
	50		230			110	71		13.0
KB31	25	136				138	51	3.40	
	32	144				152	51	5.70	
	40	150				152	62	6.90	
	50	180				152	71	8.80	
KB33	25		160			138	51		5.9
	32		180			152	51		9.1
	40		200			152	62		11.2
	50		230			152	71		13.4
KC31	40	150				152	62	6.90	
	50	180				187	71	9.10	

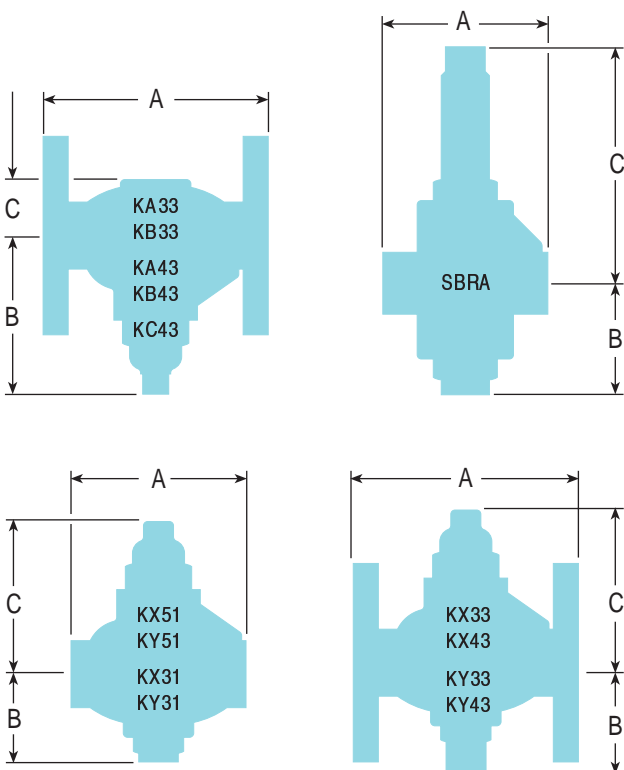

Valve model	Size DN	BSP NPT A	PN 16 A	PN 25 / 40 A	ANSI *150 300 A	B	C	Weight kg	
								Scrd	Flgd

Cast iron

BMFRA	15		130			87			3.6
KX31	15	90				68	106	1.50	
	20	104				68	106	1.80	
	25	136				80	108	3.30	
	32	144				80	112	5.30	
	40	150				90	112	6.40	
	50	180				100	112	7.90	
KX33	15		130			68	106		3.4
	20		150			68	106		4.4
	25		160			80	108		5.8
	32		180			80	112		8.9
	40		200			90	112		11.1
	50		230			100	112		13.1
KY31	32	144				80	154	6.10	
	40	150				90	154	7.30	
	50	180				100	154	9.00	
KY33	32		180			80	154		9.2
	40		200			90	154		11.3
	50		230			100	154		13.5

Normally open valves for heating applications

Valve model	Size DN	BSP	PN	PN	ANSI	B	C	Weight kg	
		NPT A	16 A	25 / 40 A	*150 300 A			Scrd	Flgd

Gunmetal

BX	15	95				83		0.70	
SB	15	79				101	66	1.00	
	20	105				101	66	1.30	
	25	121				101	66	1.50	
KA51	25	136				107	51	3.96	
	32	144				110	51	6.20	
	40	150				110	62	7.52	
	50	180				110	71	9.35	
KB51	25	136				138	51	4.17	
	32	144				152	51	7.00	
	40	150				152	62	8.32	
	50	180				152	71	10.30	
KC51	40	150				152	62	8.32	
	50	180				187	71	10.60	
NS	65	171		203	*203	150	150	8.10	17.2
	80	194		236	*236	160	160	13.60	22.7

Valve model	Size DN	BSP	PN	PN	ANSI	B	C	Weight kg	
		NPT A	16 A	25 / 40 A	*150 300 A			Scrd	Flgd

Cast carbon steel

BM	15				130	127	87		3.6
KA43	15				130	130	105		4.3
	20				150	150	105		6.3
	25				160	162	105		8.0
	32				180	180	110		8.7
	40				200	202	110		9.7
KB43	50				230	232	110		14.6
	25				160	162	138		8.2
	32				180	180	152		9.1
KC43	40				200	202	152		10.1
	50				230	232	152		15.0
	32				180	180	152		9.1
KC43	40				200	202	152		10.1
	50				230	232	187		15.3

Normally closed valves for cooling applications

Valve model	Size DN	BSP	PN	PN	ANSI	B	C	Weight kg	
		NPT A	16 A	25 / 40 A	*150 300 A			Scrd	Flgd

Gunmetal

BXRA	15	95				83		0.70	
SBRA	15	79				66	95	1.00	
	20	105				66	95	1.30	
	25	121				66	95	1.50	
NSRA	65	171		203	*203	150	150	8.10	17.2
	80	194		236	*236	160	160	13.60	22.7
KX51	25	136				80	108	4.10	
	32	144				80	112	6.32	
	40	150				90	112	7.62	
	50	180				100	112	9.50	
KY51	32	144				80	154	7.25	
	40	150				90	154	8.57	
	50	180				100	154	10.60	

Valve model	Size DN	BSP	PN	PN	ANSI	B	C	Weight kg	
		NPT A	16 A	25 / 40 A	*150 300 A			Scrd	Flgd

Cast carbon steel

BMRA	15				130	127	87		3.6
KX43	15				130	130	68	106	4.4
	20				150	150	68	106	6.4
	25				160	162	80	108	8.1
	32				180	180	80	112	8.8
	40				200	202	90	112	9.8
KY43	50				230	232	100	112	14.7
	32				180	180	80	154	9.2
	40				200	202	90	154	10.2
KY43	50				230	232	100	154	15.1

Limiting conditions

	Gunmetal	Cast iron	Cast carbon steel	
Body design conditions	PN25	PN16	PN25	PN40
Maximum design temperature	260°C	220°C	300°C	300°C
Maximum cold hydraulic test	38 bar g	24 bar g	38 bar g	60 bar g

Gunmetal operating chart

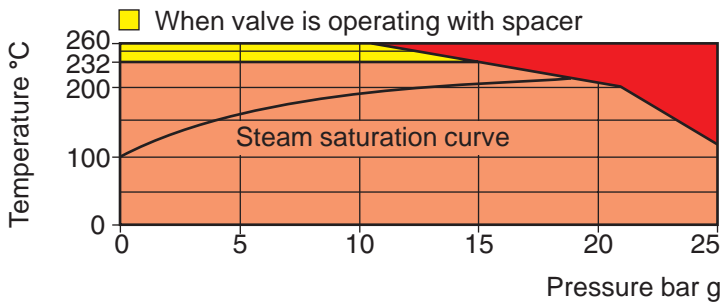

■ The product must not be used in this area

Note: KB51 and KY51 maximum temperature 232°C

Cast iron operating chart

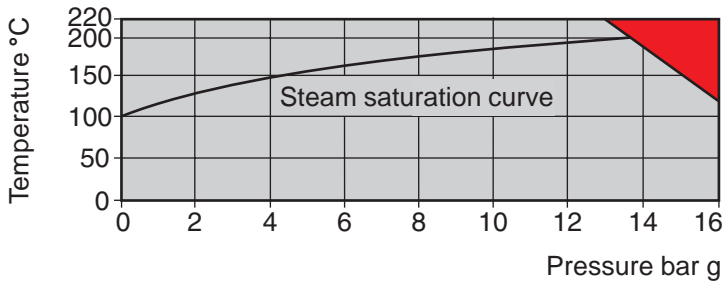

■ The product must not be used in this area

Cast carbon steel operating chart

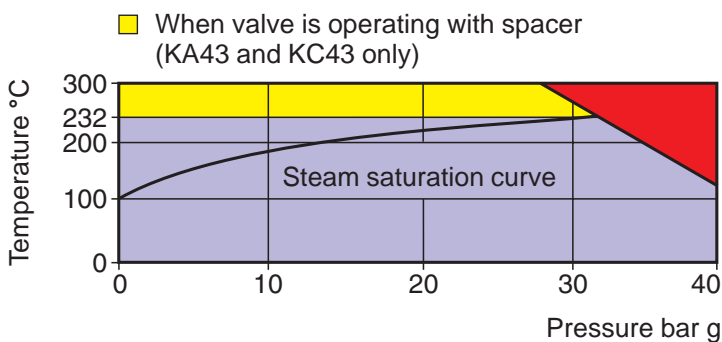

■ The product must not be used in this area

Note: KB43 and KY43 maximum temperature 232°C

Control system selection

The control systems are available in four configurations as shown below.
Each type is available with either a dial or knob type temperature adjustment except the Type 422.
Dimensions approximate in mm

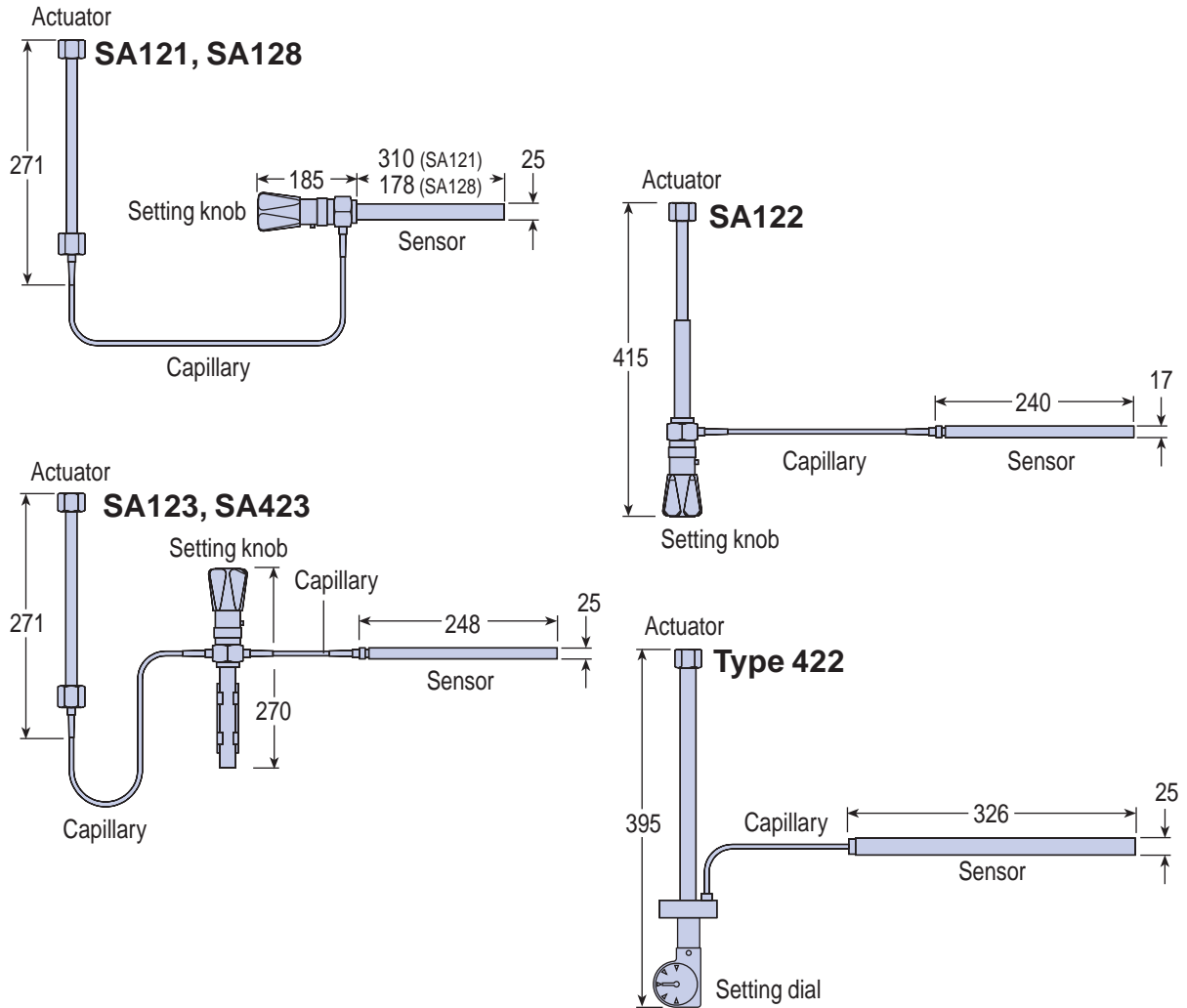

Specifications

Type	Range	Temperature	Maximum sensor temperature	Material	Weight kg	Standard capillary tube (m)
SA121	1	-15 to 50°C	55°C over set value to max. 190°C	Brass	2.0	2, 4, 8 and 20
	2	40 to 105°C				
	3	95 to 160°C				
SA122	1	-20 to 120°C	55°C over set value	Brass	1.8	2, 4, 8, and 20
	2	40 to 170°C				
SA123	1	-15 to 50°C	55°C over set value	Brass	2.5	2, 4, 8, and 20
	2	40 to 105°C				
	3	95 to 160°C				
SA128	1	-20 to 110°C	55°C over set value to max. 190°C	Brass	1.8	2, 4, 8, and 20
	2	40 to 170°C				
Type 422	C	25 to 60°C	55°C over set value	Stainless steel	1.4	2.4 or 4.8 *
	D	50 to 85°C				
	E	70 to 105°C				
SA423	1	-15 to 50°C	55°C over set value	Stainless steel sensor remainder brass	2.5	2, 4, 8, and 20
	2	40 to 105°C				
	3	95 to 160°C				

* Longer lengths up to 9.6 m are available to special order

Control system ancillaries

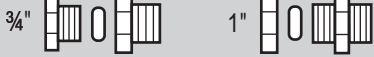
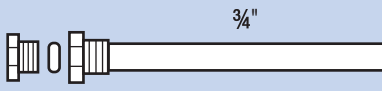
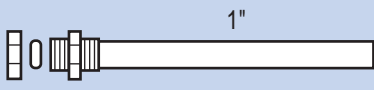
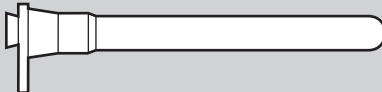
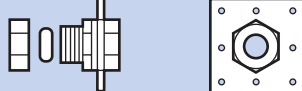
Mounting options		Control system type					
		SA121	SA122	SA123	SA128	Type 422	SA423
Standard pocket immersion length (mm)		315	258	258	180	326	258
Size (BSP or NPT)		1"	¾"	1"	1"	1"	1"
	Wall mounting bracket	•	•	•	•		
	Union kit for sensor immersion without pocket	•	•	•	•	•	•
	Mild steel pocket longer pocket option *	•	•	•	•		
	Stainless steel pocket longer pocket option *	•	•	•	•		•
	Copper pocket longer pocket option *	•	•	•	•		
	Brass pocket longer pocket option *	•	•	•	•		
	Glass pocket with bracket and rubber bung		•	•			•
	Duct fixing kit	•		•	•		

* Special long pockets are available in lengths from 0.5 m to 1 m.

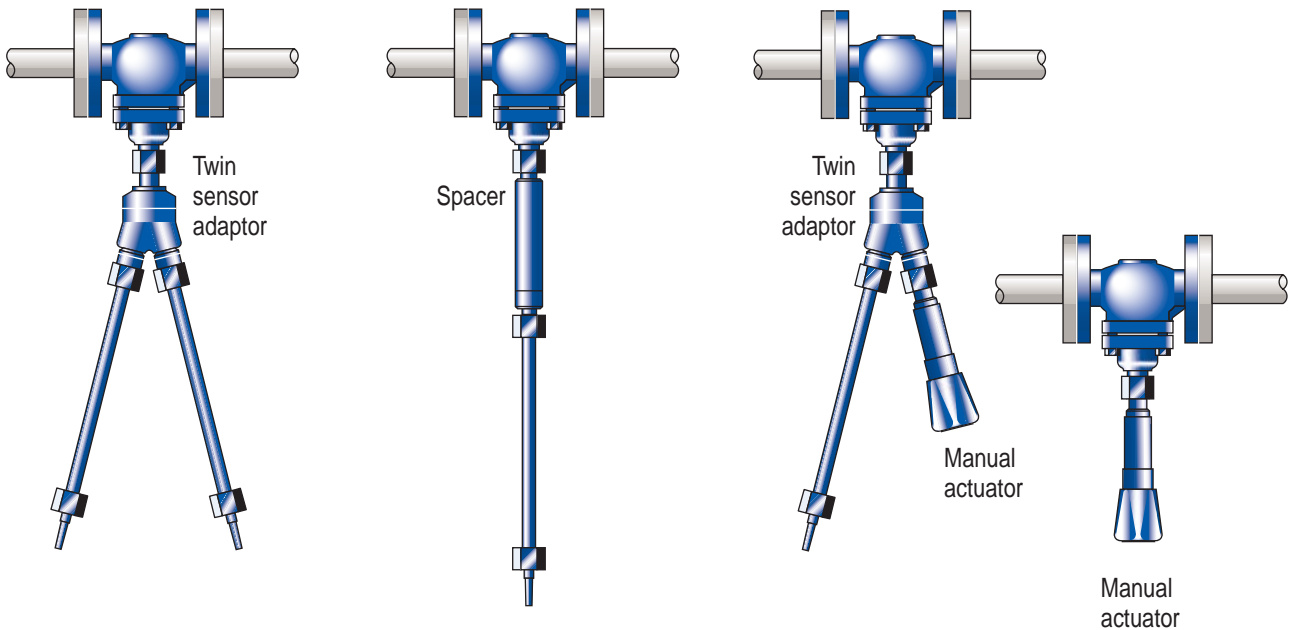

Twin sensor adaptor

When coupled to a valve allows operation by two actuators.

Materials	Brass
Dimensions	A 108 mm B 60 mm
Weight	0.72 kg

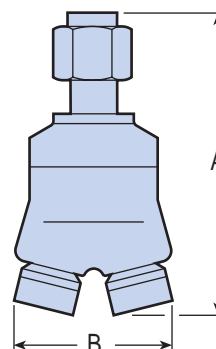

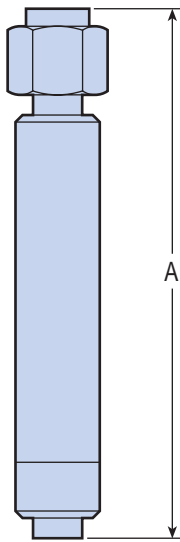

Spacer

Each valve has its individual limiting conditions, but when coupled to a control system, these are governed by the brass actuator which is limited to 232°C. Installing the spacer between the valve and the control system enables the system to operate at a maximum temperature of 350°C.

Note: The maximum temperature under the limiting conditions for each valve should be checked in case it is below 350°C.

Materials	Case	Brass BS 2871 part 2 CZ162 (1972)
	Bellows	Stainless steel AISI 316
Dimensions	A 145 mm	
Limiting conditions	Maximum pressure 25 bar g	
	Maximum temperature 350°C	

Manual actuator



When coupled to a valve, it enables the valve to be manually operated.

Materials	Brass with plastic adjustment head	
Dimensions approximate in mm	A	125
	B	54
Weight	0.2 kg	

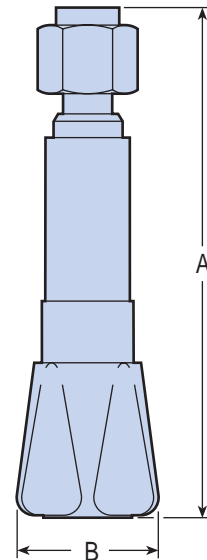

Simple rules to remember when installing self-acting control systems

Immersion in good steady flow conditions gives fast response and stable control. Remember, heating systems with secondary mixing valves will require a by-pass to avoid no flow conditions around the sensor controlling the primary medium.

Sensors should be immersed fully, taking care not to extend the pipe boss beyond 25 mm from the pipe wall.

Where possible, fix sensors into pipework horizontally so that air is not trapped within the boss (see below).

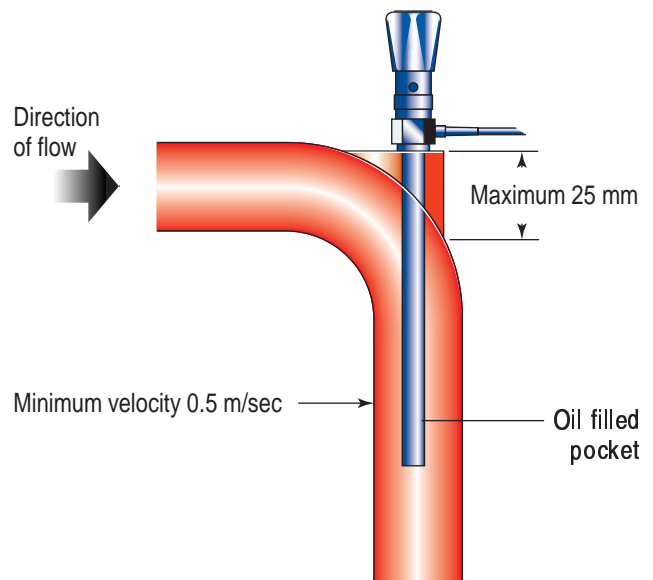
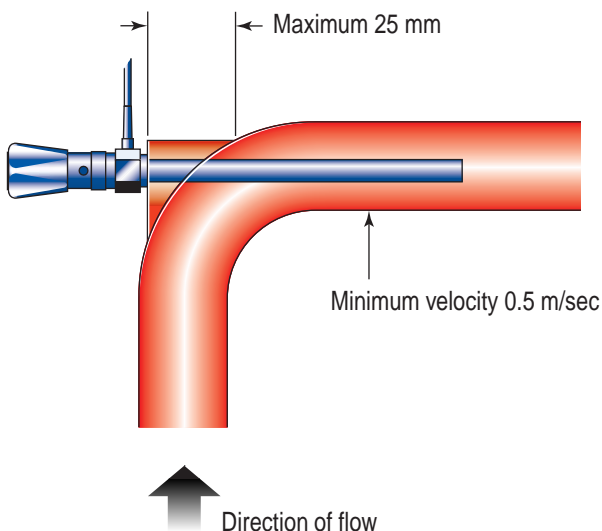

When sensors are immersed in fluids a pocket is recommended to allow removal of the thermostatic sensor without the need to drain the system. Pockets are available in stainless steel, mild steel, brass, copper and for very corrosive applications, glass.

When using pockets, always fill them with a heat conductive paste. Where pockets are installed vertically then a light oil can be used.

Safeguard

The self-acting safeguard against overheating

Why fit a Safeguard?

Even the best temperature controls can fail, often through no fault of their own. Whatever the cause, the effect of a failure can be serious and may lead to injury or even loss of life.

The Spirax Sarco Safeguard automatically shuts off heat at its source in the event of a temperature overrun.

- Protects people from scalding.
- Protects plant.
- Highlights control system failure.

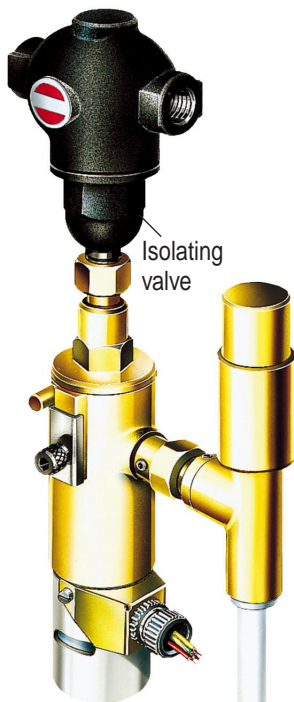

HL10

Type 130 control system

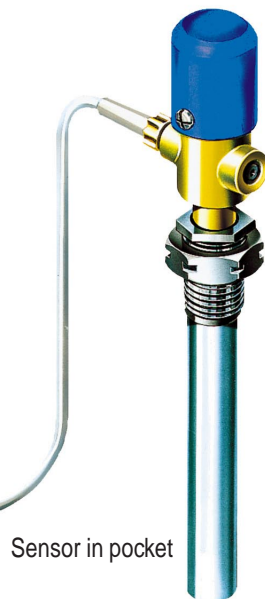

Sensor in pocket

Type 130 control system

The Type 130 control system is the sensing device and features:

- Self-acting operation.
- A factory set temperature of 60°C but can be adjusted between 0°C and 100°C.
- Fails safe even if capillary is damaged.
- Standard capillary length 2 m. Maximum 10 m in multiples of 2 m.

HL10

The HL10 snaps the isolating valve shut if the pre-set high limit temperature is exceeded.

The HL10 features:

- Manual reset.
- Visual red indicator.
- Micro switch facility for remote audio/visual indicator.

Where to fit?

- Preventing temperature overrun on hot water services in accordance with many Health and Safety regulations.
- Preventing temperature overrun on heating calorifiers.
- EMS, BMS interfaceable to flag excess temperatures.

How it works

The Type 130 control system continually monitors the controlled temperature. If the pre-set temperature is exceeded, the expansion of the system fill causes the actuating mechanism to release a ball catch in the HL10 and a powerful spring snaps the valve shut.

- The manual reset feature highlights the system failure and demands attention to the problem.
- Sensor pockets available in mild steel, copper, stainless steel.
- Valves available in gunmetal, cast iron and cast steel in sizes DN15 to 50.

Some of the products may not be available in certain markets.

Spirax-Sarco Limited, Charlton House,
Cheltenham, Gloucestershire, GL53 8ER UK.
Tel: +44 (0)1242 521361 Fax: +44 (0)1242 573342
E-mail: Enquiries@SpiraxSarco.com
Internet: www.SpiraxSarco.com

© Copyright 2000 Spirax Sarco is a registered trademark of Spirax-Sarco Limited

spirax
sarco

SB-F11-07

CH Issue 5