



Cert. No. LRQ 0963008

ISO 9001

# spirax sarco

## MST21

TI-P125-08  
ST Issue 8

## Stainless Steel

# Balanced Pressure Thermostatic Steam Trap

### Description

The MST21 is a maintainable balanced pressure thermostatic steam trap designed for relatively small condensate loads usually associated with instrument tracing applications. It is manufactured in stainless steel and is corrosion resistant and easily maintainable.

### Available types

**MST21** Standard capacity for tracing loads (standard unit)

**MST21H** High capacity for special applications

**Note:** When placing an order always state the capsule fill.

### Capsule fill and operation

**Standard capsules** are marked with the letter '**STD**' for operation at approximately 10°C below steam saturation temperature.

**Optionally** the capsule can be supplied for sub cooled '**SUB**' operation at approximately 22°C below steam saturation temperature or a '**NTS**' fill capsule for operation at approximately 4°C below steam saturation temperature.

### Standards

This product fully complies with the requirements of the European Pressure Equipment Directive 97/23/EC.

### Certification

This product is available with a manufacturers' Typical Test Report.  
**Note:** All certification/inspection requirements must be stated at the time of order placement.

### Sizes and pipe connections

**MST21** 1/4", 3/8" and 1/2" screwed BSP, EN ISO 228-1, or NPT.

**MST21H** 1/2", 3/4" and 1" screwed BSP, EN ISO 228-1, or NPT.

### Pressure/temperature limits (ISO 6552)

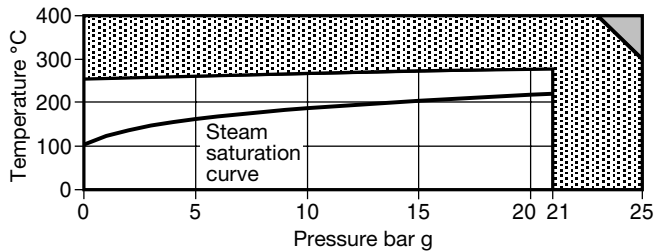

The product **must not** be used in this region.

The product **should not** be used in this region as damage to internals may occur.

Body design conditions		PN25
PMA	Maximum allowable pressure	25 bar g @ 300°C
TMA	Maximum allowable temperature	400°C @ 23 bar g
Minimum allowable temperature		0°C
PMO	Maximum operating pressure	21 bar g @ 270°C
TMO	Maximum operating temperature	270°C @ 21 bar g
Minimum operating temperature		0°C
Designed for a maximum cold hydraulic test pressure of 38 bar g		

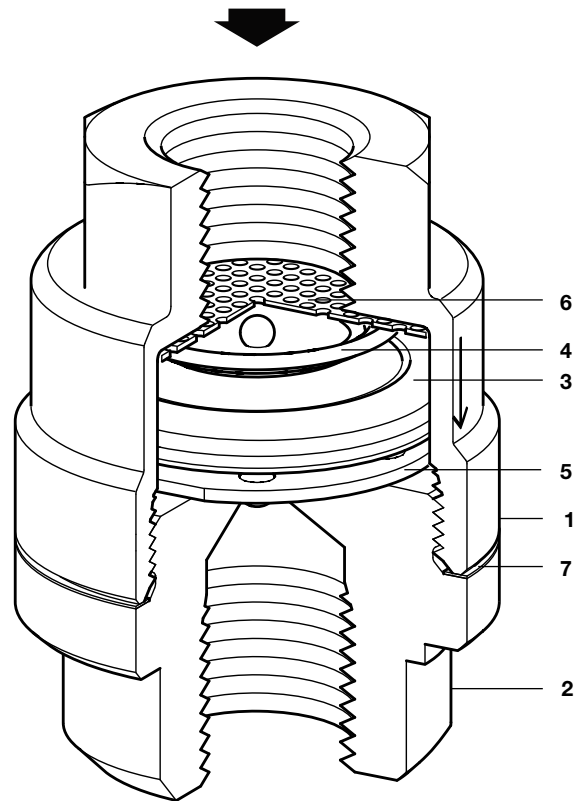

### Materials

No. Part	Material	
1 Body	Austenitic stainless steel (316)	ASTM A743 CF16Fa
2 Cap	Stainless steel	420A UGIMA AISI 420
3 Capsule	Stainless steel	
4 Spring	Stainless steel	BS 2056 302 S26
5 Spacer plate	Stainless steel	BS 1449 304 S15
6 Strainer screen (0.8 mm perforations)	Stainless steel	ASTM A240 316L
7 Gasket	Stainless steel	BS 1449 304 S15

**Note:** Material grades shown in brackets are nearest equivalents.

## Capacities

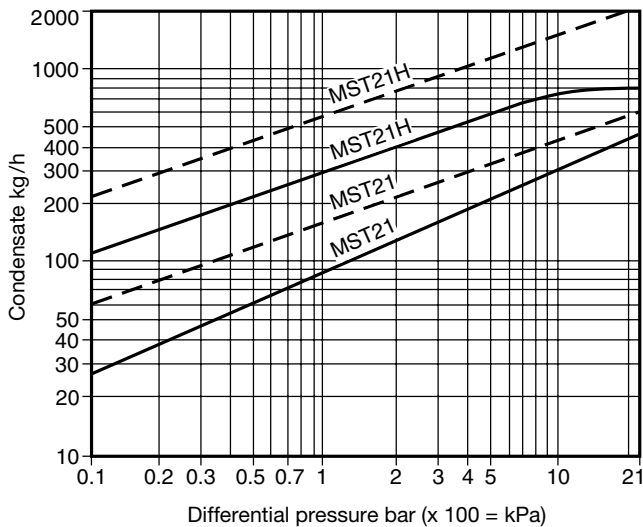

Cold water capacity - - - - - Hot water capacity —————

## Dimensions / weights (approximate) in mm and kg

Size	A	B	C	D	Weight
¼"	50.5	8.5	10	45	0.34
½"	61.0	12.5	14	45	0.48
¾"	68.0	14.0	14	45	0.48
¾"	68.0	14.0	14	45	0.48
1"	75.0	14.0	14	45	0.48

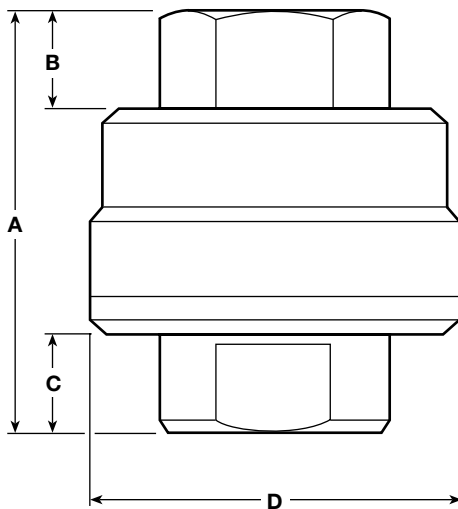

## Safety information, installation and maintenance

For full details see the Installation and Maintenance Instructions (IM-P125-07) supplied with the product.

### Installation note:

The MST21 is designed for installation with the capsule in a vertical line with the inlet at the top and the outlet at the bottom. This will ensure it is self-draining. If fitted in a horizontal line the trap should be preceded by a short drop-leg.

### Caution:

The body/cover gasket contains a thin stainless steel support ring, which may cause physical injury if it is not handled and disposed of carefully.

### Disposal:

This product is recyclable. No ecological hazard is anticipated with the disposal of this product, providing due care is taken.

## How to order

**Example:** 1 off Spirax Sarco ¼" MST21 balanced pressure thermostatic steam trap having a 'STD' fill capsule for operation approximately at 10°C below steam saturation temperature. The connections are to be screwed NPT.

## Spare parts

The spare parts available are shown in solid outline. Parts drawn in broken line are not supplied as spares.

### Available spares

Internals set for MST21 3, 4, 5, 6, 7

### How to order spares

Always order spares by using the description given in the column headed 'Available spares' and state the size, model number and capsule reference.

**Example:** 1 off Internals set for a Spirax Sarco ¼" MST21 balanced pressure thermostatic steam trap having a 'STD' fill capsule for operation at 10°C below steam saturation temperature.

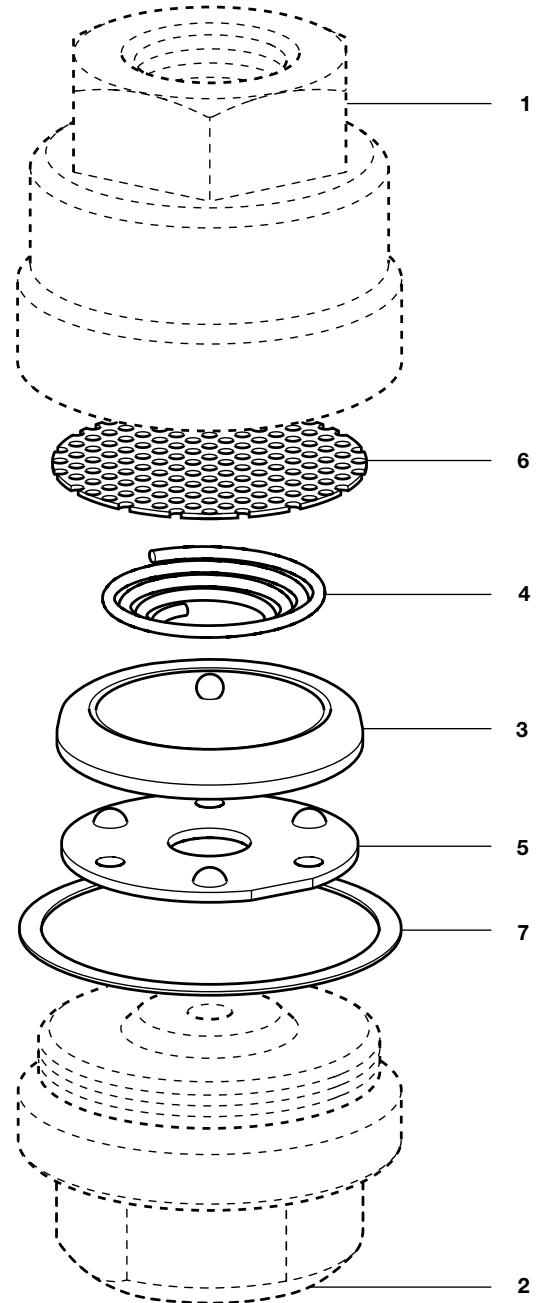

## Recommended tightening torques

Item	Size	or	mm	N m
1 and 2	¼"		22	100 - 110
	½"		32	100 - 110
	¾"		32	100 - 110
	¾"		36	100 - 110
	1"		41	100 - 110